

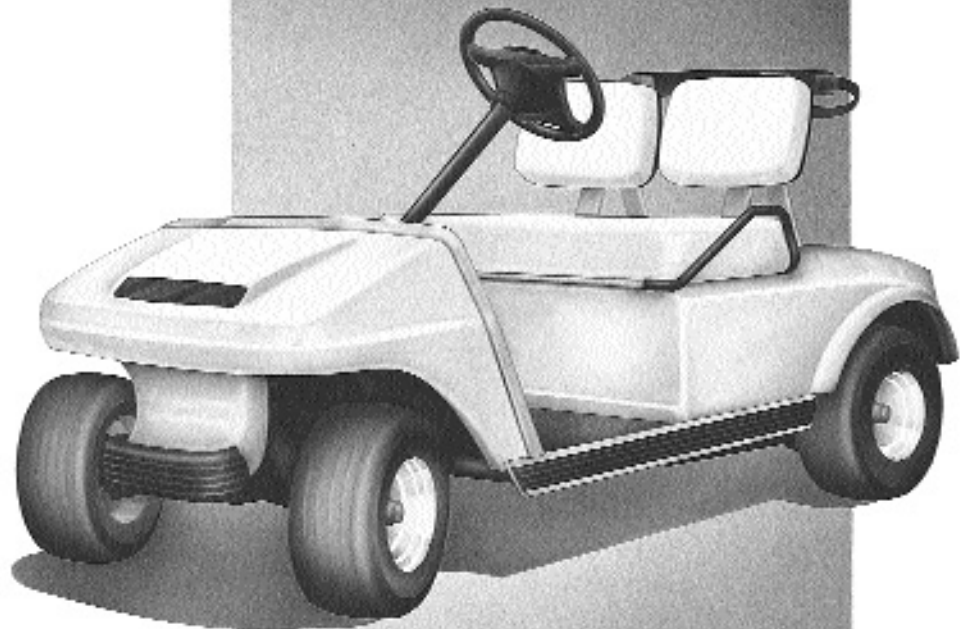

**1995 DS ELECTRIC  
GOLF CAR WITH  
POWERDRIVE SYSTEM 48**

**MAINTENANCE  
SERVICE  
SUPPLEMENT**



**USE WITH 1994  
DS GASOLINE/ELECTRIC  
MAINTENANCE AND  
SERVICE MANUAL**

**PUBLICATION PART NO.1018293-05  
PRINT CODE 0695B0895A**



# SECTION 17B - DS ELECTRIC VEHICLES WITH POWERDRIVE SYSTEM 48

## WARNING

- ONLY TRAINED TECHNICIANS SHOULD REPAIR OR SERVICE THIS VEHICLE. ANYONE DOING EVEN SIMPLE REPAIRS OR SERVICE SHOULD HAVE SOME KNOWLEDGE AND EXPERIENCE IN GENERAL ELECTRICAL REPAIR. FOLLOW ALL PROCEDURES EXACTLY AND HEED ALL WARNINGS STATED IN THIS MANUAL.
- ALWAYS WEAR SAFETY GLASSES OR APPROVED EYE PROTECTION WHILE SERVICING VEHICLE. WEAR A FULL FACE SHIELD WHEN WORKING WITH BATTERIES.
- TURN KEY SWITCH OFF, PLACE FORWARD AND REVERSE LEVER IN THE NEUTRAL POSITION, AND REMOVE KEY PRIOR TO SERVICING.
- DO NOT WEAR LOOSE CLOTHING. REMOVE JEWELRY SUCH AS RINGS, WATCHES, CHAINS, ETC. BEFORE SERVICING VEHICLE.
- ALWAYS USE INSULATED TOOLS WHEN WORKING NEAR BATTERIES OR ELECTRICAL CONNECTIONS.
- TO AVOID UNINTENTIONAL STARTING OF THE VEHICLE, **DISCONNECT BATTERIES** AS SHOWN IN FIGURE 17-1, AND THEN **DISCHARGE THE CONTROLLER** AS FOLLOWS:
  - TURN THE KEY SWITCH TO "ON" AND PLACE THE FORWARD AND REVERSE LEVER IN THE REVERSE POSITION .
  - SLOWLY DEPRESS THE ACCELERATOR PEDAL AND KEEP IT DEPRESSED UNTIL THE REVERSE WARNING BUZZER CAN NO LONGER BE HEARD. WHEN THE BUZZER STOPS SOUNDING, THE CONTROLLER IS DISCHARGED.

## DANGER

- **BATTERIES RELEASE EXPLOSIVE GASSES!** KEEP ALL SOURCES OF IGNITION (CIGARETTES, SPARKS, FLAMES) AWAY FROM CHARGING AND SERVICE AREAS. CHARGING AND SERVICE AREAS SHOULD BE WELL VENTILATED TO PREVENT BUILD-UP OF EXPLOSIVE GASSES.
- **USE EXTREME CAUTION** WHEN USING TOOLS, WIRES, OR METAL OBJECTS NEAR BATTERIES! A SHORT CIRCUIT AND (OR) SPARK COULD CAUSE AN EXPLOSION.
- **BATTERIES CONTAIN ACID** THAT IS POISONOUS AND CAN CAUSE SEVERE BURNS!  
**BATTERY ACID ANTIDOTES:**
  - EXTERNAL: FLUSH WITH WATER. **CALL PHYSICIAN IMMEDIATELY.**
  - INTERNAL: DRINK LARGE QUANTITIES OF WATER OR MILK. FOLLOW WITH MILK OF MAGNESIA OR VEGETABLE OIL. **CALL PHYSICIAN IMMEDIATELY.**
  - EYES : FLUSH WITH WATER FOR 15 MINUTES. **CALL PHYSICIAN IMMEDIATELY.**

## GENERAL INFORMATION

Club Car has manufactured two versions of the PowerDrive System 48 vehicle. The earlier version used a multi-step (wiper switch) potentiometer in the speed control circuit, whereas the current version, beginning with week A9529, uses a continuously variable potentiometer. Both versions feature a 48 volt electrical system, including an on-board computer that controls the battery charger, monitors vehicle energy usage, and provides test data to the optional Communication Display Module.

### General Information Continued:

To properly service and maintain this vehicle, it is necessary to understand the electrical circuitry and the functions of all the electrical components. On any PowerDrive System 48 vehicle, there are four separate circuits in operation: 1) the control circuit, 2) the speed control circuit, 3) the power circuit, and 4) the charge circuit. A reverse buzzer is also included on every vehicle (See Page 17-29). When working on the electrical system, refer to the appropriate electrical wiring diagram (Figures 17-2 and 17-3, Pages 17-3 and 17-4) for more detailed information.

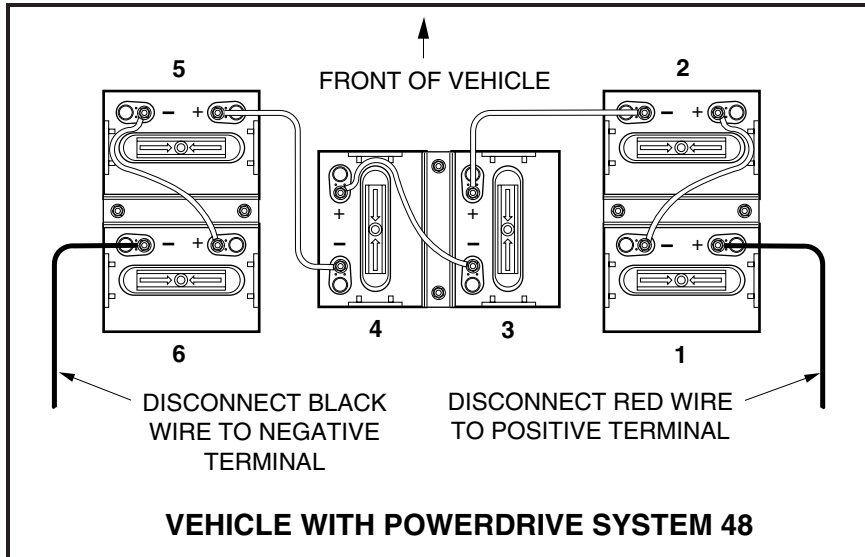

FIGURE 17-1

## THE ON-BOARD COMPUTER (OBC)

Each PowerDrive System 48 vehicle is equipped with an on-board computer (OBC). The primary function of the on-board computer is to control the battery charger. By continuously monitoring battery state of charge, as well as the amount of energy consumed as the vehicle is used, the OBC is able to direct the battery charger to replace exactly the amount of energy needed to replenish the batteries. The OBC uses this data also to indicate possible battery or charging problems by illuminating a warning light in the dash (For more information on the Battery Trouble Light, see Section 19, Page 19-2). OBC data can also be useful in performing electrical system diagnostics. A digital readout of OBC data can be obtained using the Club Car Communication Display Module (CDM)(Club Car Part No. 1018318-01)(See page 17-22).

The chart in Figure 17-4, Page 17-6 is a quick reference guide to troubleshooting vehicle symptoms that might be OBC related.

## POWERDRIVE VEHICLE ELECTRICAL CIRCUITS

### NOTE

- TO SERVICE THE ELECTRICAL SYSTEM, IT IS NECESSARY TO HAVE A CONTINUITY TESTER OR A VOLT-OHM METER CAPABLE OF READING FROM 0 - 48 VOLTS DC. THE VOM (PART NO. 1011480) AND CONTINUITY TESTER (PART NO. 1011273) ARE AVAILABLE FROM YOUR LOCAL AUTHORIZED DEALER OR FROM CLUB CAR SERVICE PARTS.

### THE CONTROL CIRCUIT

The control circuit consists of the key switch, F&R (Forward and Reverse) anti-arcing limit switch, accelerator limit switch, solenoid, and connecting wires.

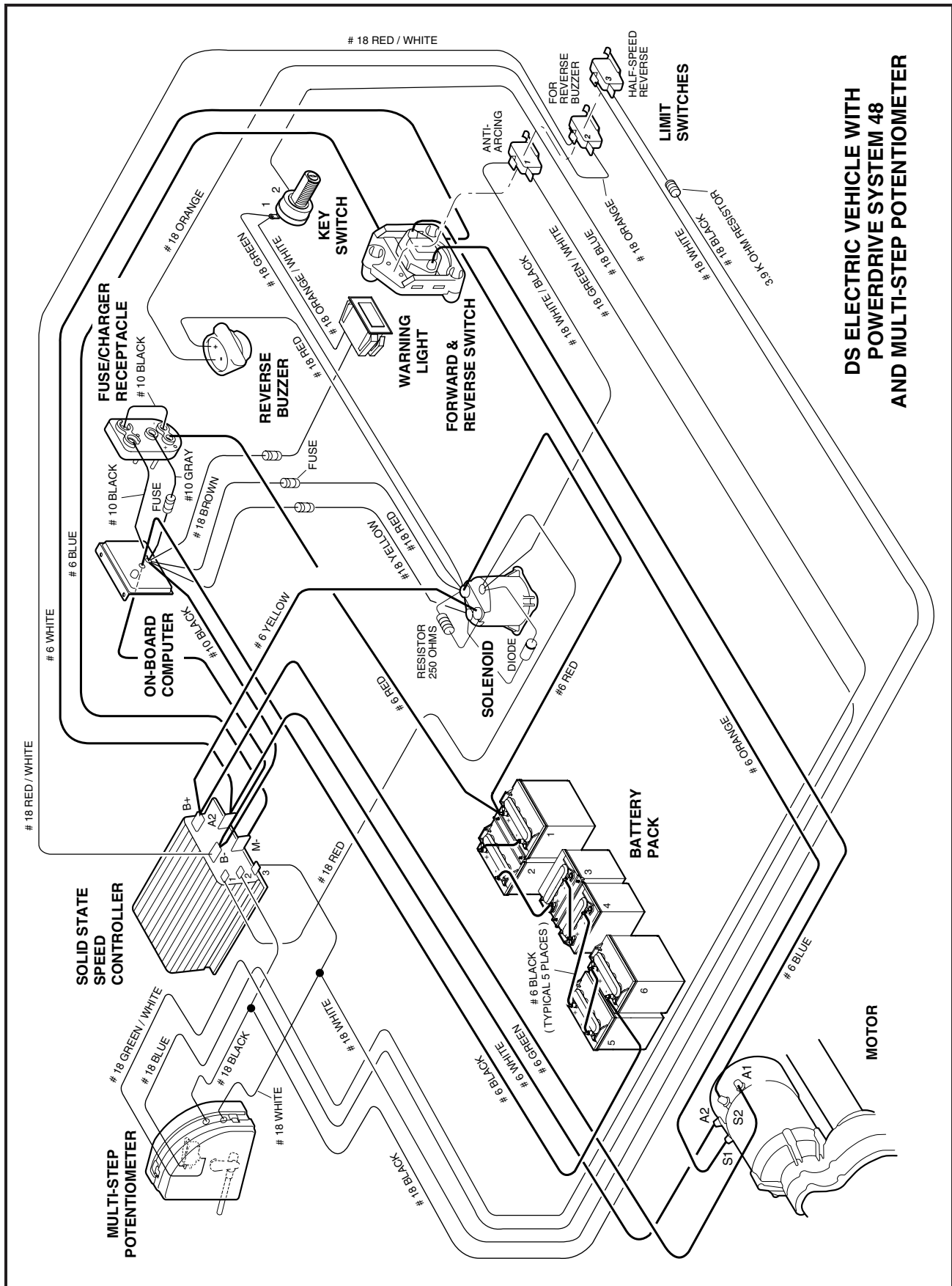

**DS ELECTRIC VEHICLE WITH  
POWERDRIVE SYSTEM 48  
AND MULTI-STEP POTENTIOMETER**

**FIGURE 17-2**

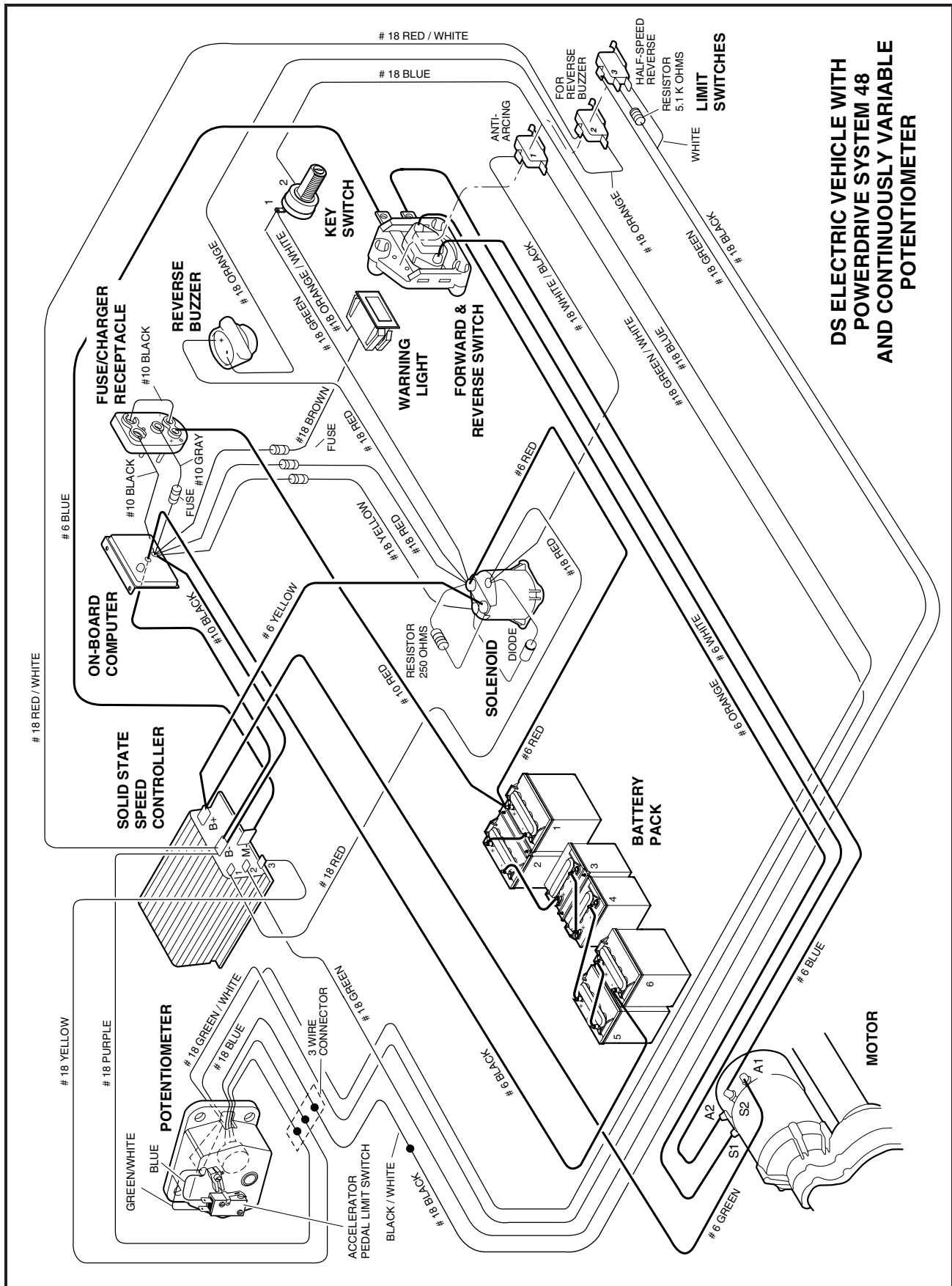

**DS ELECTRIC VEHICLE WITH  
POWERDRIVE SYSTEM 48  
AND CONTINUOUSLY VARIABLE  
POTENTIOMETER**

**FIGURE 17-3**

### **The Control Circuit Continued:**

The key switch is an “on-off” type, the function of which is to disable, or open, the control circuit when the vehicle is not in use. With the key switch in the “off” position, the vehicle will not run.

The function of the F&R anti-arcing limit switch is to prevent arcing on the F&R contacts. When the vehicle is in neutral, the limit switch is open. The F&R anti-arcing limit switch closes only after full contact has been made on the F&R switch. As the F&R switch is being disengaged, the F&R anti-arcing limit switch opens the power circuit by opening the solenoid before the F&R contacts are separated. By using the F&R anti-arcing limit switch to control power through the F&R switch, arcing is prevented on the F&R contacts.

When the accelerator is depressed (which closes the potentiometer limit switch), and the F&R switch is in forward or reverse (which closes the anti-arcing limit switch), and the key is in the “on” position, the control circuit is complete. The solenoid coil (enclosed in solenoid) will then be activated, closing the solenoid power contacts and activating the controller.

The reverse buzzer is a warning device that is activated when the F&R switch is placed in reverse. The reverse buzzer will sound continuously until the vehicle is shifted to neutral or forward.

### **THE POWER CIRCUIT**

The power circuit consists of the solid state speed controller, solenoid contacts, forward and reverse (F&R) switch, motor, batteries, and all power wiring. The motor and batteries will be discussed in separate sections in this manual (**Motor - Section 20, and Batteries - Section 18**).

The solid state speed controller provides smooth and efficient vehicle acceleration and deceleration by precisely controlling voltage input (corresponding to accelerator position) to the motor.

The F&R switch changes the direction of vehicle movement by changing the direction of electrical current through the motor, and thus the direction that the motor turns.

### **THE SPEED CONTROL CIRCUIT**

#### **Multi-step Potentiometer (Wiper Switch) Models:**

The speed control circuit consists of the multi-step potentiometer with discrete resistors. With the car in forward, the potentiometer resistance varies from 0 ohms with the accelerator pedal up (at rest position) to approximately 4940 ohms with pedal fully depressed (for full-speed operation, resistance must be above 4600 ohms and below 7000 ohms). When the vehicle is put into reverse, a limit switch is engaged that brings an additional resistor into the circuit at the F&R limit switch No. 3. This reduces vehicle top speed in reverse to approximately half of forward top speed.

#### **Continuously Variable Potentiometer Models:**

The speed control circuit consists of a solid state three-wire potentiometer. With the car in forward, the potentiometer resistance varies from approximately 0 to 300 ohms with the accelerator pedal up (at rest position) to approximately 5500 ohms with pedal fully depressed (for full-speed operation, resistance must be above 4600 ohms and below 7000 ohms). When the vehicle is put into reverse, a limit switch is engaged that brings an additional resistor into the circuit at the F&R limit switch No. 3. This reduces vehicle top speed in reverse to half of forward top speed.

### **THE CHARGE CIRCUIT**

The charge circuit consists of the on-board computer, battery charger, DC charger plug, charger receptacle, receptacle fuse link, and the 8-volt batteries. The batteries and the battery charger will be discussed in separate sections in this manual (**Batteries - Section 18, and Battery Charger - Section 19**).

The charger plug and receptacle connection is the most critical between the charger and the vehicle’s battery circuit. The contacts in the receptacle must grip the plug pins well enough to create enough pressure or drag for an adequate electrical connection. If little or no drag is felt, the receptacle or plug must be replaced. If the plug or receptacle is damaged, or feels hot when charging, one or both must be replaced (**See Plug and Receptacle, Section 19**).

The on-board fuse link provides additional protection to the vehicle charging circuit. The fuse is rated for use only with a Club Car PowerDrive charger. If it is blown, the cause should be determined before it is replaced. A vehicle with a blown fuse will not charge (**See Receptacle Fuse Link, Section 19**).



# TROUBLESHOOTING GUIDE

## DIAGNOSTIC REFERENCE CHARTS

Use these charts as a starting point for system troubleshooting. More detailed system testing instructions follow these charts.

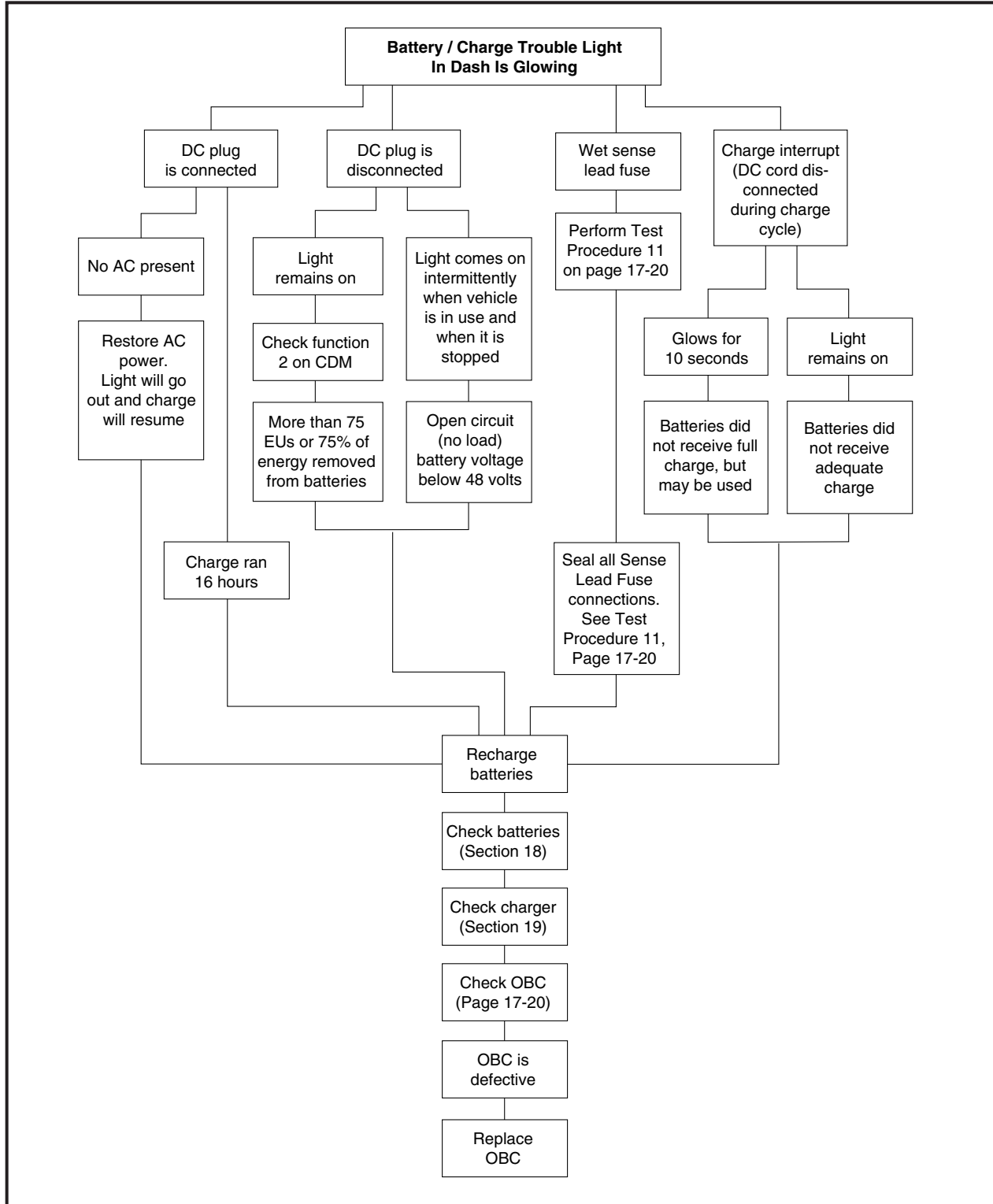

FIGURE 17-4



## POWERDRIVE TROUBLE SHOOTING GUIDE

SYMPTOM	PROBLEM	POSSIBLE CAUSES	REFER TO
1. Vehicle will not run - no solenoid "click"	Batteries	1) battery connections 2) batteries discharged	Test Procedure 1
	Key Switch	1) loose wires 2) failed switch	Test Procedure 2
	F&R Anti-arcing Limit Switch	1) loose wires 2) failed switch 3) cam not activating switch	F&R Anti-arcing Limit Switch, Electrical Components, Section 17C
	Solenoid	1) loose wires 2) failed coil	Test Procedure 5
	Accelerator	1) accelerator rod disconnected	Accelerator, Pedal, & Rod Adjustment Section 21
	Accelerator Pedal Limit Switch	1) loose wires 2) failed switch 3) improperly wired	Test Procedure 4
	Diode	1) failed diode	Diode, Electrical Components, Section 17C
	Controller Electrical Leakage	1) dirt or acid residue on controller	Test Procedure 10
	On-board Computer	1) battery connections 2) on-board computer solenoid lockout failure	Figure 17-1 Test Procedure 11
2. Vehicle will not run - solenoid "clicks"	Batteries	1) battery connections 2) batteries discharged	Test Procedure 1
	Solenoid	1) loose wires 2) failed power contacts	Figure 17-1 or 17-2 Test Procedure 7
	F&R Switch	1) loose wires 2) failed contacts	Test Procedure 6
	Potentiometer	1) loose wires 2) improperly wired 3) short or open circuit 4) improperly adjusted	Figure 17-1 or 17-2 Test Procedure 9
	Controller	1) loose wires 2) defective controller	Test Procedure 10
	Motor	1) loose wires 2) open/shorted windings	Motor, Section 20

## POWERDRIVE TROUBLE SHOOTING GUIDE

SYMPTOM	PROBLEM	POSSIBLE CAUSES	REFER TO
3. Vehicle runs slowly	Wiring	1) improperly wired	Figure 17-2 or 17-3
	Batteries	1) loose terminals or corrosion 2) improper wiring 3) failed batteries 4) discharged batteries	Test Procedure 1 & Battery, Section 18  Battery Charger, Section 19
	Motor	1) loose wires 2) defective motor	Motor, Section 20
	Potentiometer	1) improperly adjusted 2) defective potentiometer	Test Procedure 9
	Brakes	1) dragging brakes	Brakes, Section 7
	Half-speed Reverse Limit Switch (3)	1) failed in close position 2) improperly wired	Test Procedure 12 Leads reversed at microswitch Figure 17-2 or 17-3
	Controller	1) vehicle overload  2) defective controller	Let controller cool - remove part of load Test Procedure 10
	Tires	1) under-inflated or flat tires	Inflate or repair tires
4. Vehicle runs full speed in reverse	F&R Half-speed Reverse Limit Switch (3)	1) loose or disconnected wires 2) failed switch	F&R Switch, F&R Limit Switch, Electrical Components, Section 17C
	5100 ohm Resistor	1) resistor disconnected or failed	Test Procedure 13
5. Vehicle will run in forward but not in reverse, or will run in reverse but not forward	F&R Anti-arcing Limit Switch	1) loose or broken wires 2) improper actuation of switch  3) improperly wired	Test Procedures 3, F&R Switch, and F&R Limit Switch, Electrical Components, Section 17C Figure 17-2 or 17-3
	F&R Switch	1) poor continuity of switch contacts	Test Procedure 6
6. Vehicle not being fully charged	Charger Connections	1) loose wires at receptacle, battery 2) improper engagement of charger plug and receptacle	Charger, Section 19
	Charger Receptacle Fuse Link	1) blown	Charger, Section 19

## POWERDRIVE TROUBLE SHOOTING GUIDE

SYMPTOM	PROBLEM	POSSIBLE CAUSES	REFER TO
6. Vehicle not being fully charged, Continued...	Charger	1) incoming AC voltage 2) charger output low 3) charger cord and plugs 4) charger relay 5) charger fuse blown	Charger, Section 19
	Charger/On-board Computer	improper charging	PowerDrive Battery Charger, Section 19
7. Vehicle runs without pressing the accelerator when the key is on and the F&R switch is in forward or reverse.	Accelerator	1) improper pedal adjustment	Accelerator Pedal & Rod Adjustment, Section 21
8. Solenoid clicks when key turned on	Accelerator Microswitch	1) defective switch 2) improper pedal adjustment	Test Procedure 4 Accelerator Pedal and Rod Adjustment, Section 21

## CIRCUIT TESTING

### WARNING

- **WHEN MAKING ELECTRICAL TESTS OR REPAIRS, ALWAYS:**
  - WEAR SAFETY GLASSES OR APPROVED EYE PROTECTION.
  - REMOVE KEY.
  - PUT F&R IN NEUTRAL.
  - DISCONNECT BATTERIES AS SHOWN, FIGURE 17-1, PAGE 17-2.
  - FOLLOW ALL PROCEDURES EXACTLY AS STATED.
- **SEE SAFETY WARNINGS PAGE 17-1.**

Using the following procedures, the entire electrical system of the PowerDrive vehicle can be tested without major disassembly of the vehicle:

- Refer to Figure 17-5 or 17-7 for testing the control circuit, and to Figure 17-6 or 17-8 for testing the power circuit.
- The red (+) and black (-) probe symbols in Figures 17-5, 17-6, 17-7, and 17-8 (wiring diagrams) indicate points where the probes should be placed for tests. The numbers on the probe symbols indicate test procedure numbers.
- A volt-ohm meter (VOM)(Club Car Part No. 1011480) or a continuity tester (Club Car Part No. 1011273) is needed in order to make these tests.
- Continuity or a closed circuit is indicated by zero ohms on the VOM or a lighted indicator on the continuity tester. No continuity, or an open circuit, is indicated by infinite ohms or no light.
- The tests on this section are made in order to check a component and the wire to and from the component. The probes will often be placed at points removed from the component being tested.

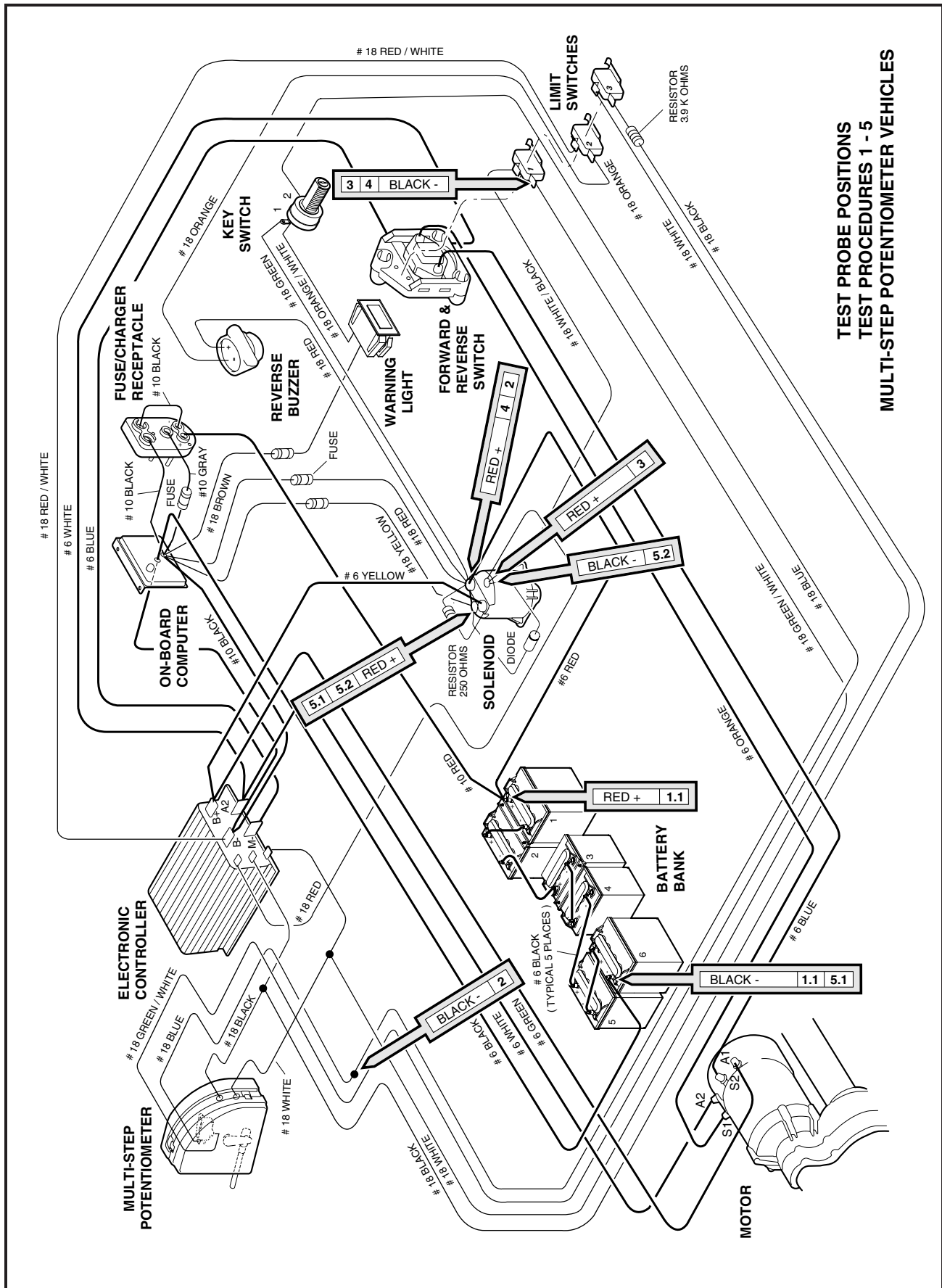

**TEST PROBE POSITIONS  
TEST PROCEDURES 1 - 5  
MULTI-STEP POTENTIOMETER VEHICLES**

**FIGURE 17-5**



## CONTROL CIRCUIT

### **WARNING**

- **WHEN MAKING ELECTRICAL TESTS OR REPAIRS, ALWAYS:**
  - WEAR SAFETY GLASSES OR APPROVED EYE PROTECTION.
  - REMOVE KEY.
  - PUT F&R SWITCH IN NEUTRAL.
  - DISCONNECT BATTERIES AS SHOWN, FIGURE 17-1, PAGE 17-2.
  - FOLLOW ALL PROCEDURES EXACTLY AS STATED.
- **SEE SAFETY WARNINGS PAGE 17-1.**

### **Test Procedure 1 - Batteries / Voltage Check:**

1. With VOM set at Volts DC, place red (+) probe on the positive post of battery No. 1, and the black (-) probe on the negative terminal of battery No. 6. If you don't read at least 48 volts with the batteries fully charged, check for loose battery connections or a battery installed in reverse polarity. Refer to Batteries, Section 18, for further details on battery testing.

### **Test Procedure 2 - Key Switch:**

#### **Vehicle with Multi-step (wiper switch) Potentiometer -**

1. Place the red (+) probe of the VOM or continuity tester on the large terminal of the solenoid (with red wire attached) and place the black (-) probe at the blue wire disconnect terminal on the key switch side.
2. With the key switch off, the reading should be no continuity. If continuity is shown, perform Test Procedure 4. If a correct reading is not obtained for Test Procedure 4, check the key switch, wires and terminals, and then replace defective parts.
3. Insert the key and turn the switch on. The reading should be continuity.
4. If the reading is incorrect, check the key switch, wires and terminals, and then replace defective parts.

#### **Vehicle with Continuously Variable Potentiometer -**

1. Place the red (+) probe of the VOM or continuity tester on the large terminal of the solenoid (with red wire attached) and place the black (-) probe at the green/white wire from the Forward/Reverse limit switch No. 1.

### **WARNING**

- TO AVOID UNTINTENTIONAL STARTING OF THE VEHICLE, DISCONNECT BATTERIES AS SHOWN IN FIGURE 17-1, PAGE 17-2, AND THEN DISCHARGE THE CONTROLLER AS FOLLOWS:
  - TURN THE KEY SWITCH TO "ON" AND PLACE THE FORWARD/REVERSE LEVER IN THE REVERSE POSITION.
  - SLOWLY DEPRESS THE ACCELERATOR PEDAL AND KEEP IT DEPRESSED UNTIL THE REVERSE WARNING BUZZER CAN NO LONGER BE HEARD. WHEN THE BUZZER STOPS SOUNDING THE CONTROLLER IS DISCHARGED.

2. Depress and hold the accelerator pedal to the floor to activate the accelerator pedal limit switch.
3. With the key switch off, the reading should be no continuity.
4. Insert the key and turn the switch on while continuing to hold the accelerator pedal down. The reading should be continuity.
5. If the reading is incorrect, check the key switch, wires and terminals, and replace defective parts.

### Test Procedure 3 - Forward/Reverse Anti-Arcing Limit Switch:

#### NOTE

- OF THE THREE LIMIT SWITCHES ON THE FORWARD/REVERSE SWITCH, THE FORWARD/REVERSE ANTI-ARCING LIMIT SWITCH IS THE ONE CLOSEST TO THE VEHICLE BODY.

1. Place the red (+) probe of the VOM or continuity tester on the small activating coil stud of the solenoid that has the white/black and red wires connected to it. Place the black (-) probe on the No. 1 anti-arcing limit switch at the normally open (NO) terminal.
2. Reading should show continuity when the Forward/Reverse lever is shifted to forward position and to reverse position (should show no continuity when in neutral and when in forward or reverse until the rotor contacts are in contact with contact bars). If not, check wires and terminals, then replace switch.

#### WARNING

- **WHEN MAKING ELECTRICAL TESTS OR REPAIRS, ALWAYS:**
  - WEAR SAFETY GLASSES OR APPROVED EYE PROTECTION.
  - REMOVE KEY.
  - PUT F&R SWITCH IN NEUTRAL.
  - DISCONNECT BATTERIES AS SHOWN, FIGURE 17-1, PAGE 17-2.
  - FOLLOW ALL PROCEDURES EXACTLY AS STATED.
- **SEE SAFETY WARNINGS PAGE 17 -1.**

### Test Procedure 4 - Accelerator Pedal Limit Switch:

#### Vehicle with Multi-step (wiper switch) Potentiometer -

1. Place the black (-) probe of the VOM on the green/white wire terminal from limit switch No. 1 and the red (+) probe on the wiper switch side of the blue wire disconnect.
2. With the accelerator pedal fully up (not depressed), the reading should be NO continuity.
3. With the key switch off, depress the accelerator pedal. The reading should be continuity.
4. If the readings for steps 2 and 3 are not correct, check for proper wire connection at the normally closed (NC) and the common (COM) terminals. Check accelerator pedal adjustment (**See Section 21**).
5. If the wires are connected correctly and the accelerator pedal is properly adjusted, but the readings still not correct, replace the switch.

#### Vehicle with Continuously Variable Potentiometer -

1. With the key switch on, connect the red lead of the VOM to the large post of the solenoid (with No. 6 red wire attached), and connect the black lead of the VOM to the green/white wire from limit switch No. 1 on the Forward/Reverse switch (**Figure 17-5 or 17-6, Page 17-10 or 17-11**).
  - 1.1. With the accelerator pedal not depressed, the reading should be no continuity.
  - 1.2. Depress the accelerator pedal and the reading should be continuity.
2. If these reading are not obtained, check to be sure that the wires are connected properly to the normally open (NO) and the common (COM) terminals. Check accelerator pedal adjustment (**See Section 21**).
3. If wires are connected correctly and the accelerator pedal is properly adjusted, but the readings are incorrect, replace the switch.







## Test Procedure 5 - Solenoid Activating Coil:

1. Remove Diode terminal end from the small post on solenoid (with 18 gauge yellow wire attached).
2. Make sure that the diode direction is correct (**Figure 17-2, Page 17-3, or Figure 17-3, Page 17-4**). The red terminal end of Diode attaches to small post on solenoid (with 18 gauge red wire and 18 gauge white/black striped wire attached).
3. Using a VOM or continuity tester, check for continuity between both diode terminals. Reverse the tester leads again and check for continuity. A diode is designed to conduct current in one direction only. If a diode shows continuity in both directions or does not show continuity in either direction, replace the diode assembly.
4. Remove the diode assembly and the yellow wire from the small activating coil post of the solenoid and place the red (+) probe of the VOM on the post. Place the black (-) probe on the other small activating coil post on the solenoid. A reading of 190 to 250 ohms should be obtained. If not, replace the solenoid.  
If the ohm reading is correct, reconnect the diode assembly and yellow wire.

## POWER CIRCUIT

### Test Procedure 6 - Forward/Reverse Switch:

1. With the Forward/Reverse selector in the forward position, place the red (+) probe of VOM or continuity tester on the M- terminal lug of the speed controller and place the black (-) probe on the S1 motor terminal. Meter should read continuity.
2. With the Forward/Reverse selector in the forward position, place the red (+) probe on the A2 motor terminal, and place the black (-) probe on the S2 motor terminal. Meter should read continuity.
3. With Forward/Reverse selector in the reverse position, place the red (+) probe on the speed controller M- terminal and place the black (-) probe on the S2 motor terminal. Meter should read continuity.
4. With the Forward/Reverse selector in the reverse position, place the red (+) probe on the A2 motor terminal and place the black (-) probe on the S1 motor terminal. Meter should read continuity.

If continuity reading cannot be obtained, and all wires and connections are correct, see Forward/Reverse Switch, Section 17C.

### Test Procedure 7 - Solenoid Contacts (Power Off):

#### **WARNING**

- **WHEN MAKING ELECTRICAL TESTS OR REPAIRS, ALWAYS:**
  - WEAR SAFETY GLASSES OR APPROVED EYE PROTECTION.
  - REMOVE KEY.
  - PUT F&R SWITCH IN NEUTRAL.
  - DISCONNECT BATTERIES AS SHOWN, PAGE 17-2.
  - FOLLOW ALL PROCEDURES EXACTLY AS STATED.
- **SEE SAFETY WARNINGS PAGE 17 -1.**

As stated in WARNING above, follow procedures exactly.

1. Remove the yellow wire and red wire from the large posts of the solenoid. Remove resistor assembly. Place the red (+) probe of the VOM on one of the large posts of the solenoid and the black (-) probe of the meter on the other large post on the solenoid. It should show no continuity. If the VOM shows continuity, replace the solenoid.
2. Using a VOM, check for continuity between both resistor terminals. If reading is not approximately 250 ohms, replace the resistor.

## SPEED CONTROL CIRCUIT

### Test Procedure 8 - Multi-step Potentiometer:

1. Disconnect the black and white No. 18 wires that are attached to controller terminals "2" and "3" (terminals "B" and "C" on early model vehicles) (see wiring diagram Figure 17-2, Page 17-3 to identify terminals) and connect ohm meter to wires.
2. Disconnect half-speed reverse resistor from the half-speed reverse limit switch.
3. Measure resistance while pressing the accelerator pedal.

The measured resistance should go up in six steps:

1st Step:	300 ohms (approx.)
2nd Step:	690 ohms (approx.)
3rd Step:	990 ohms (approx.)
4th Step:	1740 ohms (approx.)
5th Step:	2740 ohms (approx.)
6th Step:	4940 ohms (approx.)

### NOTE

- IT MAY BE DIFFICULT TO DETECT THESE STEPS. HOWEVER, IF AN INCREASE IN RESISTANCE FROM 0 TO (APPROXIMATELY) 5000 OHMS IS OBTAINED WHEN THE ACCELERATOR PEDAL IS DEPRESSED FROM THE REST POSITION TO FULL SPEED POSITION WITHOUT EXCEEDING (APPROXIMATELY) 7000 OHMS DURING OR AT THE END OF ACCELERATOR TRAVEL, THEN THE SPEED SWITCH RESISTOR ASSEMBLY IS IN GOOD CONDITION.

4. If the resistance steps were not correct and the accelerator pedal is properly adjusted, then replace multi-step potentiometer.
5. Reconnect black and white wires to terminals "2" and "3" ("B" and "C") as shown in Figure 17-6.
6. Reconnect half-speed reverse resistor to half-speed reverse limit switch on the Forward/Reverse switch.

### Test Procedure 9 - Continuously Variable Potentiometer:

1. Disconnect the three-wire connector (connects the potentiometer to the Forward/Reverse wire harness) from the Forward/Reverse wire harness. The connector emerges from under the floorboard into the battery compartment below the charger receptacle on the front seat support panel (Figure 17-9).
2. Connect multi-meter, set to "ohms" position, between the purple and yellow wire terminals. Resistance should read between 150 and 300 ohms at exactly the point that the limit switch is activated.
3. Depress the accelerator to the floor; potentiometer resistance should measure between 4600 and 6400 ohms.

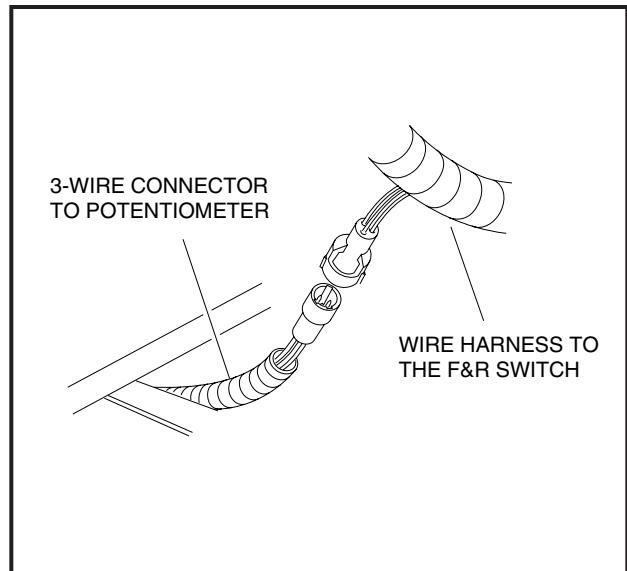

FIGURE 17-9

## Test Procedure 10 - Solid State Speed Controller:

### DANGER

- TURN KEY SWITCH TO OFF, PUT THE F&R SWITCH IN NEUTRAL, AND DISCONNECT THE BATTERY CABLES AS SHOWN IN FIGURE 17-1, PAGE 17-2. FAILURE TO DO THIS MAY CAUSE THE VEHICLE TO RUN OVER YOU, RESULTING IN SEVERE INJURY OR DEATH!

### WARNING

- TO AVOID ELECTRICAL SHOCK, DISCHARGE THE CONTROLLER AS FOLLOWS:
  - TURN THE KEY SWITCH TO “ON” AND PLACE THE FORWARD/REVERSE LEVER IN THE REVERSE POSITION.
  - SLOWLY DEPRESS THE ACCELERATOR PEDAL AND KEEP IT DEPRESSED UNTIL THE REVERSE WARNING BUZZER CAN NO LONGER BE HEARD. WHEN THE BUZZER STOPS SOUNDING THE CONTROLLER IS DISCHARGED.
  - TURN THE KEY SWITCH TO “OFF” AND PLACE THE FORWARD/REVERSE LEVER IN THE NEUTRAL POSITION.
- WHEN MAKING ELECTRICAL TESTS OR REPAIRS, ALWAYS WEAR APPROVED EYE PROTECTION OR SAFETY GLASSES. FOLLOW ALL PROCEDURES EXACTLY AS STATED.

1. Because the solid state speed controller is a sealed solid state unit, it requires almost no maintenance. It is recommended, however, that the following 2 operations be done occasionally.
  - 1.1. Make sure that the electrical connections to the controller (as well as those to the motor, batteries, etc.) are tight. When checking the controller bus bar connections for tightness, be sure to use the double-wrench technique to avoid stressing the bus bars and cracking the seals.
  - 1.2. Remove from the terminal area any corrosion or accumulations of dirt, acids, fertilizers, etc. It is especially important that the controller terminal face be free of these substances. Their presence could lead to electrical leakage and cause faulty operation.

### NOTE

- PRIOR TO ATTEMPTING THE FOLLOWING TESTS, THE REAR OF THE VEHICLE MUST BE RAISED AND SECURED ON JACK STANDS WITH THE DRIVE WHEELS OFF THE GROUND.

### WARNING

- LIFT ONLY ONE END OF UNLOADED VEHICLE AT A TIME. CHOCK THE WHEELS AND LOCK BRAKES PRIOR TO LIFTING. USE A SUITABLE LIFTING DEVICE (CHAIN HOIST OR HYDRAULIC FLOOR JACK), WITH 454 KILOGRAMS (1000 LBS) MINIMUM LIFTING CAPACITY. **DO NOT** USE LIFTING DEVICE TO HOLD VEHICLE IN RAISED POSITION. ALWAYS USE APPROVED JACK STANDS OF PROPER WEIGHT CAPACITY TO SUPPORT VEHICLE.

2. Check for solenoid input.
  - 2.1 Remove No. 6 white wire from A2 motor terminal and secure it so that it will not make contact with any live components or connections.

- 2.2. Reconnect batteries (**Figure 17-1, Page 17- 2**).
- 2.3. Place the Forward/Reverse Switch in either forward or reverse, turn the key on, and depress the accelerator pedal until limit switches turn on. This should cause the solenoid to operate with an audible click.
- 2.4. Connect the VOM across the solenoid small activating posts. You should read full battery voltage.
3. Check for controller input voltage.
  - 3.1. Place the Forward/Reverse Switch in either forward or reverse, turn the key on, and depress the accelerator pedal until limit switches turn on. This should cause the solenoid to operate with an audible click.
  - 3.2. Remove the 18 gauge red wire from controller input terminal "1" ("A" on early controllers)(**Figure 17-6 or 17-8, Page 17-11 or 17-14**).
  - 3.3. Place the VOM black probe (-) on the "B-" terminal of the controller (with No. 6 black wire attached) and the red probe (+) into the terminal end of the red wire removed from the controller terminal "1". You should read full battery voltage.
  - 3.4. If the controller input terminal is not getting full battery voltage, then check wire and connections between the solenoid small post and controller "1" ("A" on early controllers) terminal. Replace defective parts.
  - 3.5. Disconnect battery wires (**See Figure 17-1, Page 17-2**). Reconnect the No. 6 white wire to the A2 motor terminal.
  - 3.6. Reconnect batteries.
4. Check for controller output.
  - 4.1. Make sure the batteries are connected.
  - 4.2. Remove the No. 6 white wire from A2 motor terminal and secure it so that it cannot make contact with any live components or connections.
  - 4.3. Connect the VOM red probe (+) to the controller B+ terminal and the black probe (-) to the controller M- terminal. The VOM will display 48 volts, which is controller capacitor voltage.
  - 4.4. Turn on the key switch, shift the forward & reverse switch to forward and watch the VOM as you depress the accelerator pedal. With the accelerator fully depressed, the VOM should show full battery voltage. If the VOM reading does not rise to full battery voltage (with a properly functioning potentiometer and correct pedal adjustment), then the controller is defective.
5. **Early 1995 vehicles with multi-step potentiometers only - check for diode output.**
  - 5.1. Disconnect battery wires as shown in Figure 17-1, Page 17-2, and discharge the controller as instructed in WARNING on Page 17-1.
  - 5.2. Remove wires from controller A2 and B+ terminals.
  - 5.3. Use an ohm meter to check the resistance between the controller A2 and B+ terminals. You are testing for presence of a diode inside the controller, so swap the two meter leads and look for a low resistance when the (+) probe is on controller A2 terminal and the (-) probe is on B+ terminal and a much higher resistance when the probes are reversed. If your meter has a diode test function, use that. If you find the diode to be shorted, the controller is defective.
  - 5.4. Attach the #6 white wire to A2 motor terminal.
  - 5.4. Reconnect wires to controller A2 and B+ terminals.



## Test Procedure 11 - On-board Computer Lockout Circuit:

1. Inspect the charger receptacle for water in the contacts. If water is found, proceed as follows:

### NOTE

- IF THE BATTERY PACK IS WET, MAKE SURE THAT THE NO. 10 GREY WIRE FROM THE RECEPTACLE IS NOT TOUCHING ANY OF THE BATTERIES. TIE WRAP NO. 10 GREY LEAD AND NO. 18 GREY WIRE TO THE WIRE HARNESS CONDUIT IF NECESSARY.

- 1.1. Disconnect the batteries as shown (**Figure 17-1, Page 17-2**).
  - 1.2. Discharge the controller (**See instructions in the WARNING on page 17-1**).
  - 1.2. Remove the receptacle from the vehicle (**See Page 19-22**).
  - 1.3. Dry the receptacle by wiping it with a clean dry cloth and by blowing into the contacts with compressed air.
  - 1.4. Inspect the black butyl material that seals the entrance of the grey sense lead into the charger receptacle (**See Figure 19-6, Page 19-14**). If lead is not sealed, remove butyl material and seal with new butyl material.
  - 1.5. Re-install the charger receptacle into the vehicle.
2. It is possible that the On-board Computer can become "locked up", causing the OBC solenoid lockout circuit to malfunction. If this condition is suspected, "reboot" the computer as follows:
    - 2.1. Make sure that the batteries are disconnected as shown (**Figure 17-1, Page 17-2**) and that the controller has been discharged (**See instructions in the WARNING on page 17-1**).
    - 2.2. Reconnect the batteries.
    - 2.3. To determine if the computer was "locked up" and that it is now functioning properly, attempt to drive the vehicle. If the problem has been corrected, the vehicle will function normally.
  3. If it is determined that computer "lockup" is not the problem, it will be necessary to by-pass the OBC solenoid lockout circuit in order to isolate the problem. Follow the procedures below:
    - 3.1. Make sure that the batteries are disconnected as shown (**Figure 17-1, Page 17-2**) and that the controller has been discharged (**See instructions in the WARNING on page 17-1**).
    - 3.2. Connect one end of a jumper wire to the small (coil) post of the solenoid (with No. 18 yellow wire attached). Connect the other end of the jumper wire to the negative post of battery No. 6.
    - 3.3. Reconnect the batteries.
    - 3.4. If the vehicle can be driven with the jumper wire attached, then the on-board computer has failed and must be replaced. If the vehicle cannot be driven with the jumper wire attached, then study the Troubleshooting Guide on pages 17-6 through 17-9 to find and check the other circuits that could cause the same symptoms.

## Test Procedure 12 - Half-speed Reverse Limit Switch (F&R Limit Switch No. 3):

1. Check for proper wiring (**Figure 17-6 or 17-8, Page 17-11 or 17-14**) and tight connections.
2. Using a continuity tester or VOM set to ohms, check continuity across common (COM) and normally open (NO); and across common (COM) and normally closed (NC) (**See Figure 17-10**).

With the limit switch lever up (not depressed), readings should be:

COM to NC: Zero (or continuity tester is illuminated)

COM to NO: Infinity (or continuity tester is not illuminated)



With the limit switch lever depressed, readings should be:

COM to NC: Infinity (or continuity tester is not illuminated)

COM to NO: Zero (or continuity tester is illuminated)

3. If meter readings are not correct, replace limit switch.

### Test Procedure 13 - Half-speed Reverse Resistor:

1. Disconnect the black lead from the half-speed reverse limit switch located on the Forward/Reverse Switch (See Figure 17-2, Page 17-3, or Figure 17-3, Page 17-4).
2. Measure Resistance.

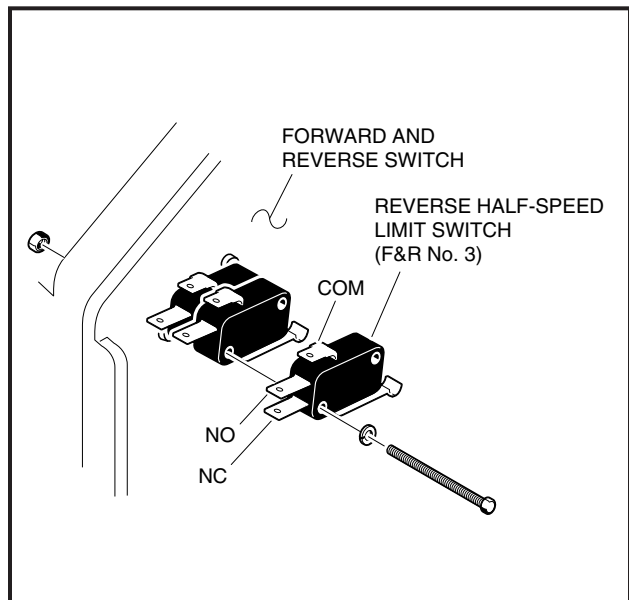

FIGURE 17-10

#### Multi-step Potentiometer Vehicle:

- 2.1. Disconnect the No. 18 black wire (from the Half-speed Reverse Limit Switch) at its connection with the No. 18 black wire from the multi-step potentiometer (See Figure 17-2, Page 17-3).
- 2.2. With a multi-meter set to ohms, measure the resistance through the No. 18 black wire from the end disconnected from the half-speed reverse limit switch to the end disconnected from terminal with the No. 18 black wire from the multi-step potentiometer. Resistance should measure approximately 3900 ohms ( $\pm 10\%$ ).

#### Continuously Variable Potentiometer Vehicle:

- 2.1. Disconnect the three-wire connector (connects the potentiometer to the Forward/Reverse wire harness) from the Forward/Reverse wire harness. The connector emerges from under the floorboard into the battery compartment below the charger receptacle on the front seat support panel (Figure 17-9, Page 17-17).
  - 2.2. With a multi-meter set to ohms, measure the resistance through the No. 18 black wire from Forward/Reverse wire harness (at disconnect from three-wire connector) to the end disconnected from the Half-speed Reverse Limit Switch. Resistance should measure approximately 5100 ohms ( $\pm 10\%$ ).
3. If the meter reading is not correct, replace the wire assembly to the limit switch.

# THE COMMUNICATION DISPLAY MODULE (CDM)

The CDM can be used to retrieve from the On-board Computer four important items of information that can be useful in troubleshooting a DS Electric vehicle with PowerDrive System 48. To access one of these items, the item's corresponding Function Code must be selected on the CDM. This is done by pressing the Function Button until the desired function code is displayed in the window (**See Figure 17-11 for CDM features**). Releasing the button when the desired code is displayed will display the desired data. Function codes and corresponding data are as follows:

- **F1 - Battery voltage:**

This displays the battery pack's current state of charge. A reading of less than 48 volts indicates that the batteries need to be charged. If a reading of less than 48 volts is obtained immediately after a charge cycle, there may be a problem in the charge circuit.

- **F2 - Energy units removed since last charge cycle:**

If the display reads over 75 (the vehicle's Battery Trouble Light should be illuminated), the vehicle's batteries need to be recharged before being used again. This data can be used to make sure that all vehicles in a fleet receive equal usage on a short term basis.

- **F3 - Total accumulated energy units removed since initial vehicle start-up:**

This information is most useful in making sure that all vehicles in a fleet receive equal usage over long periods of time.

- **F4 - Last charge termination type (1 = incomplete, 2 = DVDT, 4 = normal, 8 = max. timer):**

A **1**, **2**, **4**, or **8** will be displayed.

**1** - Indicates that the last charge cycle was incomplete and that the batteries were not fully charged. Batteries should be charged again at the earliest opportunity.

**2** - Indicates that a back-up charge program was employed by the OBC to complete the charge cycle. A DVDT charge may be displayed the first few times a new set of batteries is charged, and also the first time a set of batteries is charged after the batteries have been disconnected and reconnected. A problem may exist if persistent DVDT readings are obtained.

**4** - Indicates that the last charge cycle was normal.

**8** - Indicates that the charger ran for sixteen hours and shut itself off without completing the charge cycle. This means that there may be a problem in the charge circuit.

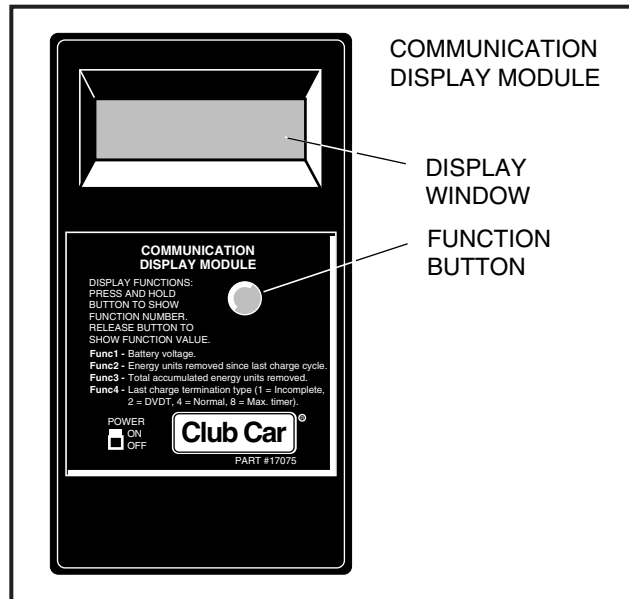

FIGURE 17-11

## USING THE CDM TO RETRIEVE DATA FROM THE ON-BOARD COMPUTER

1. Turn the CDM on and press and release the function button until desired function appears.
2. Position the CDM under the rear of the vehicle so that it is aligned directly behind the on-board computer (**Figure 17-12, Page 17-23**). Make sure the CDM's infra-red LED receiver is pointed at the on-board computer's LED, and that there is a clear path between them (**See NOTE at top of Page 17-23**).

## NOTE

- FOR BEST RESULTS, THE CDM BODY SHOULD BE POSITIONED AT APPROXIMATELY 45° TO GRADE (**FIGURE 17-13**). THE CDM MAY NOT PICK UP THE ON-BOARD COMPUTER DATA STREAM IF CDM IS NOT POSITIONED PROPERLY WITH A CLEAR AND DIRECT PATH FROM THE CDM LED TO THE ON-BOARD COMPUTER LED.

3. Wait approximately 30 seconds for a value to appear in the display window.
4. If a value does not appear in the display window after 30 seconds, try adjusting the aim of the CDM slightly and repeating step 4 until a value appears.

Once a value has been obtained in the display window, the CDM may be removed from its receiving position and the data reviewed. The CDM will hold the values for F1, F2, F3, and F4 until the CDM is turned off or it receives another line of data from the same or another on-board computer. Use the following procedure to review the data stored in the CDM:

1. The value currently displayed will be F1 (battery voltage).
2. To view F2, press and hold the button on the CDM. When “Func 2” appears in the display window, release the button. The value for F2 will then be displayed.
3. To view F3, press and hold the button on the CDM until “Func 3” appears in the display window. Release the button. The value for F3 will be displayed.
4. To view F4, press and hold the button on the CDM until “Func 4” appears in the display window. Release the button. The value for F4 will be displayed.

## NOTE

- THE VALUES OF ALL FOUR FUNCTIONS CAN BE RECALLED BY PRESSING AND RELEASING THE CDM BUTTON.

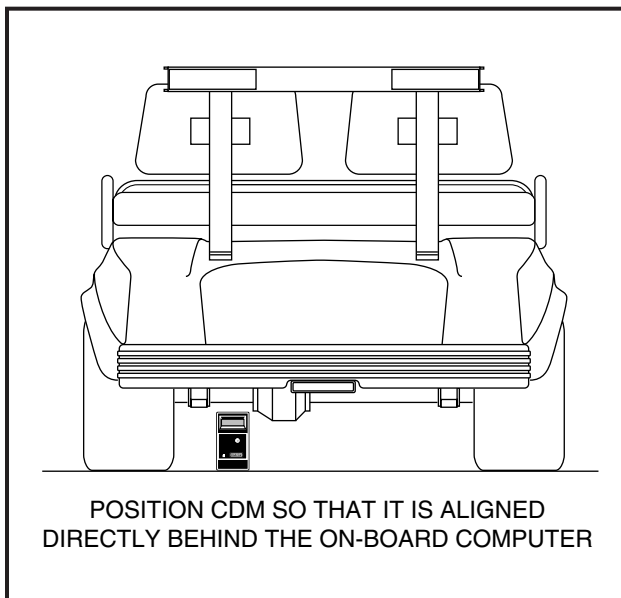

FIGURE 17-12

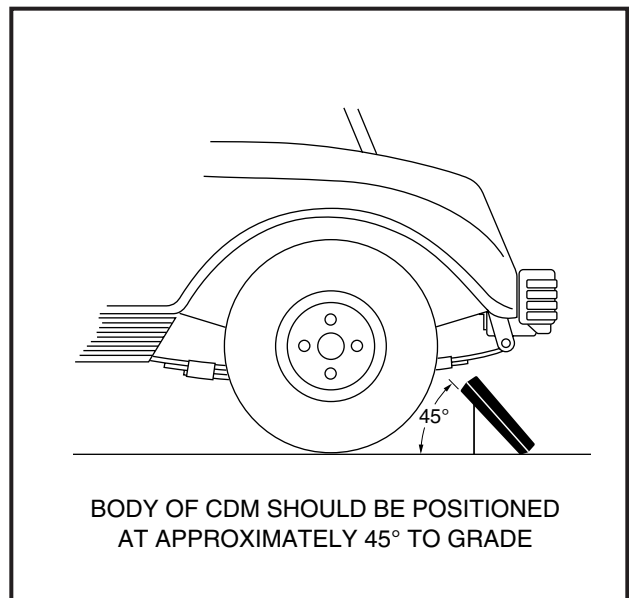
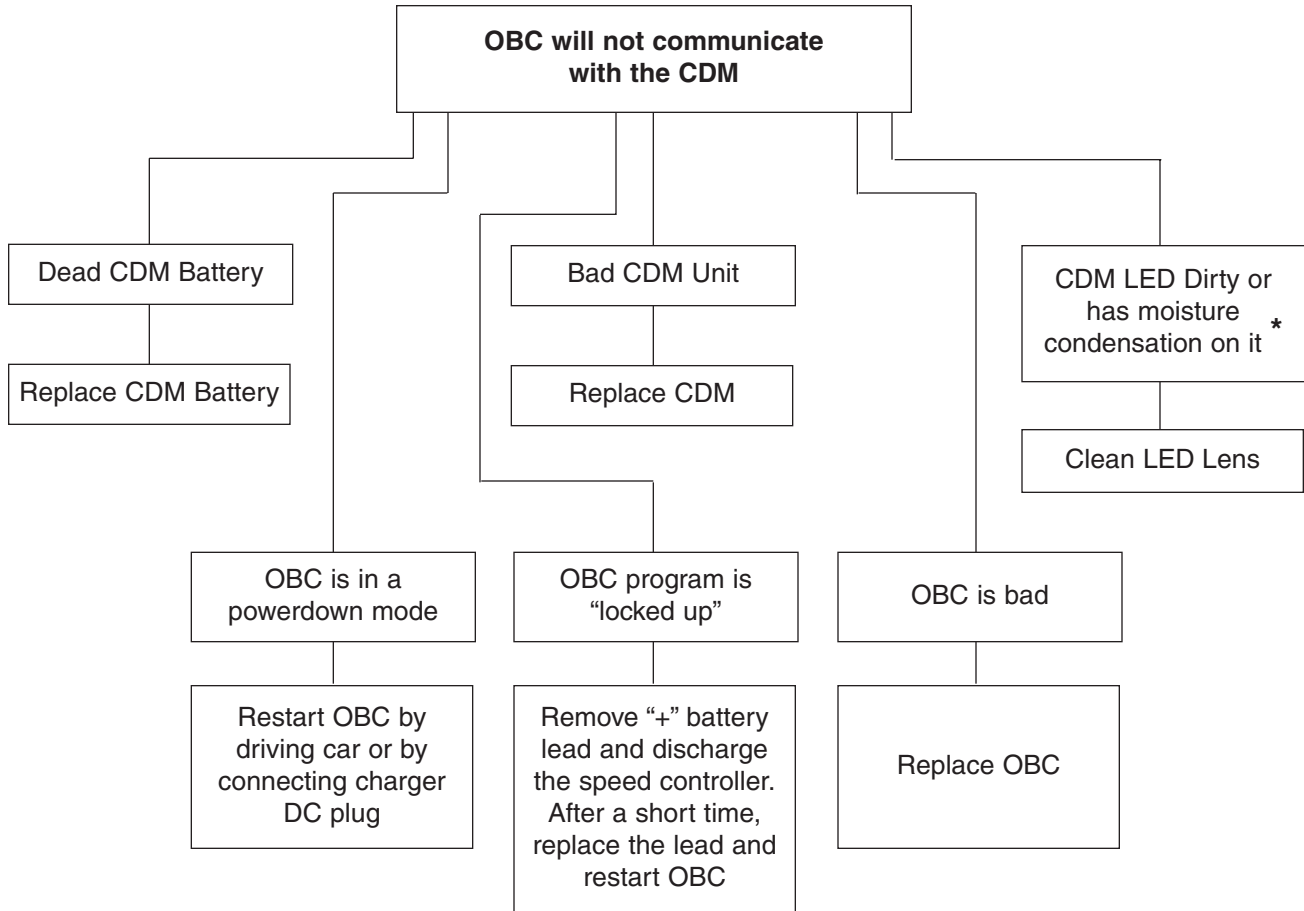

FIGURE 17-13

# COMMUNICATION DISPLAY MODULE TROUBLESHOOTING GUIDE

Use this chart as a starting point for troubleshooting problems with communications between the CDM and on-board computer. Contact your Club Car representative for more comprehensive information.



\* On some 1995 PowerDrive System 48 vehicles manufactured between weeks 9526 and 9546, the infra-red light projection lens (LED) in the on-board computer may be partially covered by a clear sealant used when assembling the computer. If this occurs, the communication display module (CDM) may not receive information from the computer. This condition may be corrected using a razor knife or a small cutting tool to remove any excess sealant material from the area around the projection lens. Use caution not to damage the lens when removing the sealant. See Club Car Service Bulletin No. 95-12 for complete information.

## SECTION 17C - ELECTRICAL COMPONENTS

### WARNING

- ONLY TRAINED TECHNICIANS SHOULD REPAIR OR SERVICE THIS VEHICLE. ANYONE DOING EVEN SIMPLE REPAIRS OR SERVICE SHOULD HAVE SOME KNOWLEDGE AND EXPERIENCE IN GENERAL ELECTRICAL REPAIR. FOLLOW ALL PROCEDURES EXACTLY AND HEED ALL WARNINGS STATED IN THIS MANUAL.
- ALWAYS WEAR SAFETY GLASSES OR APPROVED EYE PROTECTION WHILE SERVICING VEHICLE. WEAR A FULL FACE SHIELD WHEN WORKING WITH BATTERIES.
- TURN KEY SWITCH OFF, PLACE FORWARD AND REVERSE LEVER IN THE NEUTRAL POSITION, AND REMOVE KEY PRIOR TO SERVICING.
- DO NOT WEAR LOOSE CLOTHING. REMOVE JEWELRY SUCH AS RINGS, WATCHES, CHAINS, ETC. BEFORE SERVICING VEHICLE.
- ALWAYS USE INSULATED TOOLS WHEN WORKING NEAR BATTERIES OR ELECTRICAL CONNECTIONS.
- TO AVOID UNINTENTIONAL STARTING OF THE VEHICLE, **DISCONNECT BATTERIES** AS SHOWN IN FIGURE 17-1, PAGE 17-2, AND THEN **DISCHARGE THE CONTROLLER** AS FOLLOWS:
  - TURN THE KEY SWITCH TO “ON” AND PLACE THE FORWARD AND REVERSE LEVER IN THE REVERSE POSITION.
  - SLOWLY DEPRESS THE ACCELERATOR PEDAL AND KEEP IT DEPRESSED UNTIL THE REVERSE WARNING BUZZER CAN NO LONGER BE HEARD. WHEN THE BUZZER STOPS SOUNDING, THE CONTROLLER IS DISCHARGED.

### DANGER

- WEAR A FULL FACE SHIELD WHEN WORKING AROUND BATTERIES BECAUSE OF THE DANGER OF AN EXPLODING BATTERY.
- **BATTERY - EXPLOSIVE GASES - DO NOT SMOKE!** KEEP SPARKS, FLAMES, CIGARETTES AWAY. TOOLS, WIRES AND METAL OBJECTS CAN CAUSE SPARKS WHEN “SHORTED” ACROSS A BATTERY. INSULATED TOOLS SHOULD BE USED. EXTREME CARE SHOULD BE TAKEN WHEN DISCONNECTING OR RECONNECTING BATTERIES. WHEN WIRES ARE DISCONNECTED, BE SURE TO KEEP THEM AWAY FROM BATTERY POSTS AND OTHER WIRES. VENTILATE WHEN CHARGING OR USING IN AN ENCLOSED SPACE TO PREVENT EXPLOSIVE GAS BUILD-UP.
- **POISON - CONTAINS ACID - CAUSES SEVERE BURNS - AVOID CONTACT WITH SKIN, EYES OR CLOTHING!**  
**BATTERY ACID ANTIDOTES:**
  - EXTERNAL - FLUSH WITH WATER. **CALL PHYSICIAN IMMEDIATELY!**
  - INTERNAL - DRINK LARGE QUANTITIES OF MILK OR WATER. FOLLOW WITH MILK OF MAGNESIA OR VEGETABLE OIL. **CALL PHYSICIAN IMMEDIATELY!**
  - EYES - FLUSH WITH WATER FOR 15 MINUTES. **CALL PHYSICIAN IMMEDIATELY!**

## THE KEY SWITCH

The key switch is mounted just to the right of the steering column on the center dash panel.

## Key Switch, Continued:

### Testing the key switch:

See Test Procedure 2, Page 17-12

### Removing the key switch:

1. Disconnect batteries (**Figure 17-1, Page 17-2**).
2. Discharge the speed controller (**See instructions in WARNING box on Page 17-25**).
3. Remove center dash.
  - 3.1. Remove the plastic cap covering the screw on each side of the center dash.
  - 3.2. Loosen (but do not remove) the screw on each side of the center dash panel.
  - 3.3. Insert screwdriver at top center of center dash between dash and cowl brace. Gently pry center dash out slightly from under edge of cowl brace.
  - 3.4. Pull center dash out approximately one inch from the frame and then bend the top right corner of the center dash panel inward while pulling the top of the panel out and down.

#### NOTE

- BENDING THE TOP RIGHT CORNER OF THE CENTER DASH INWARD WHILE REMOVING IT WILL PREVENT THE CONTACTS ON THE REAR OF THE KEY SWITCH FROM TOUCHING THE METAL FRAME AROUND THE DASH.

4. Slide center dash panel up the steering column by snapping out the top and then rotating the panel out and up. There is sufficient slack in the wiring to allow for this.
5. Disconnect the wires from the key switch. Do not allow wires to touch.
6. Remove key switch from the dash by holding the key switch and turning the nut on the outside of the dash with the switch tool (CLUB CAR Part No. 1012801 or 1" hex socket).

### Installing the key switch:

Reconnect wires to key switch (**See Figure 17-2, Page 17-3, or Figure 17-3, Page 17-4**). Coat the terminals with Battery Protector Spray (CLUB CAR Part No. 1014305) to ward off corrosion. Reinstall in reverse order of removal. Be sure that key switch terminals can not touch the frame and that the panel is properly seated and snapped in place.

## FORWARD AND REVERSE SWITCH (FIGURE 17-14, PAGE 17-28)

### WARNING

- **WHEN MAKING ELECTRICAL TESTS OR REPAIRS, ALWAYS:**
- WEAR SAFETY GLASSES OR APPROVED EYE PROTECTION.
- REMOVE KEY.
- DO NOT WEAR LOOSE CLOTHING. REMOVE JEWELRY SUCH AS RINGS, WATCHES, CHAINS, ETC. BEFORE SERVICING VEHICLE.
- PUT F&R SWITCH IN NEUTRAL.
- **DISCONNECT BATTERIES** AND DISCHARGE SPEED CONTROLLER.
- FOLLOW ALL PROCEDURES EXACTLY AS STATED.

## DANGER

- **TURN KEY SWITCH TO OFF AND REMOVE KEY, PUT THE F&R SWITCH IN NEUTRAL, AND DISCONNECT THE BATTERY CABLES AS SHOWN IN FIGURE 17-1, PAGE 17-2. FAILURE TO DO THIS MAY CAUSE THE VEHICLE TO RUN OVER YOU, RESULTING IN SEVERE INJURY OR DEATH!**

### Testing the Forward/Reverse Switch:

1. Refer to Power Circuit Testing - **Test Procedure 6, Page 17-16.**
2. Visually inspect rotor and contacts; be sure contacts are in good condition. If they are not, replace the whole F&R switch. If severe arcing has occurred, check F&R anti-arcing limit switch for proper operation. **See Test Procedure 3, Page 17-13, and F&R Limit Switches, below.**

### Removing the F&R switch:

1. Remove F&R handle (6) by removing screw (7) (**Figure 17-14, Page 17-28**).
2. Remove screws (8) and nuts (9) that mount the F&R switch to the rear body.
3. Pull the F&R switch away from rear body and out of the battery compartment for ease of service.
4. If wires must be disconnected from F&R switch, label them so they will be reconnected properly.

### Servicing the F&R switch:

1. Keep the switch clean.
2. If the switch is hard to turn or sticks, a light spray of WD-40® may be applied to the contacts.

## WARNING

- **DO NOT GREASE CONTACTS. THIS COULD CAUSE THE F&R SWITCH TO MALFUNCTION OR BURN.**

### Installing the F&R switch:

Install switch in reverse order of disassembly.

## CAUTION

- **BE SURE THE WIRES HAVE BEEN ROUTED SO THAT THE F&R ROTOR DOES NOT PULL ON OTHER WIRES AS THE F&R HANDLE IS SHIFTED.**

## F&R LIMIT SWITCHES

The F&R anti-arcing limit switch, reverse buzzer limit switch, and reverse half-speed limit switch are located on the F&R switch and are activated by a cam on the F&R switch rotor (**Figure 17-14, Page 17-28**).

### Testing the limit switches:

1. **F&R Anti-Arcing Limit Switch: Test Procedure 3, Page 17-13.**
2. **Reverse Buzzer Limit Switch: Testing The Reverse Buzzer Circuit, Page 17-29.**
3. **Reverse Half-Speed Limit Switch: Test Procedure 12, Page 17-20.**

### Removing the limit switches:

1. Remove all three limit switches from F&R switch by removing two screws (5), lock washers (4) and nuts (3). Label each wire prior to disconnecting wire terminals from each switch.



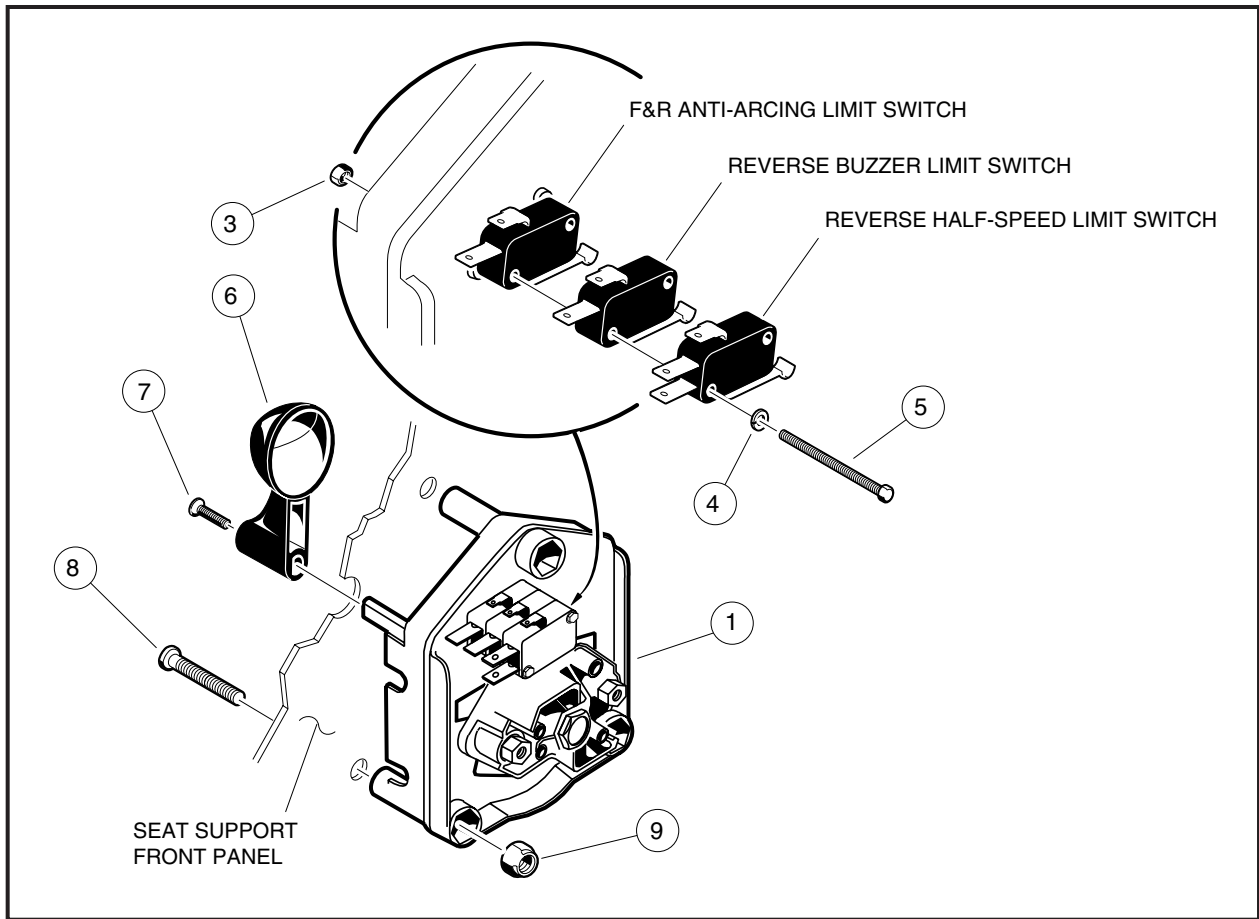

FIGURE 17-14

Limit Switch	F&R Lever Position	
	Forward	Reverse
F&R Anti-arcing	Depressed	Depressed
Half-speed Reverse	Released	Depressed
Reverse Buzzer	Released	Depressed

**F&R Limit Switches Continued:**

**Installing limit switches:**

Install in reverse order of disassembly. Insert labeled wires on the common (COM) terminal and labeled wires on the normally open (NO) terminal of each switch. Torque screws to 5 in.lbs. (0.6 N-m). **(If wires were not labeled during removal, see Figure 17-2, Page 17-3, or Figure 17-3, Page 17-4 for proper wiring.)**

After installation, be sure that when the rotor is turned, the lever arm of each switch is pressed and released per chart above. If not correct, inspect the F&R rotor and limit switches for damage.

**HALF-SPEED RESISTOR - ( TO HALF-SPEED REVERSE LIMIT SWITCH)**

The half-speed resistor assembly is connected to the half-speed reverse limit switch on the F&R switch **(Figure 17-14)**.

## Testing the half-speed resistor:

See Test Procedure 13, Page 17-21

## Removing the half-speed resistor:

Tool to be used: Wire Stripper/Crimper

1. Cut the No. 18 black wire between the failed resistor and wire harness.
2. Remove the failed resistor from the limit switch.

## Installing the half-speed resistor:

1. Using the wire stripper/crimper, strip the wire from the harness back 5.6 mm (1/4 inch).
2. Insert wire end into butt connector on new resistor wire assembly (CLUB CAR Part No. 1018830-01).
3. Using the wire crimper, crimp the butt connector to permanently attach it to the wire from the harness.
4. Install the terminal of the resistor wire assembly onto the the half-speed reverse limit switch.

**ACCELERATOR ADJUSTMENT** - See Section 21 of the 1994 Maintenance & Service Manual or Service Bulletin No. 95-5 at the end of this supplement.

## THE REVERSE BUZZER

The reverse buzzer is mounted on the rear of the center dash panel, under the front body.

### **WARNING**

- **WHEN MAKING ELECTRICAL TESTS OR REPAIRS, ALWAYS:**
- WEAR SAFETY GLASSES OR APPROVED EYE PROTECTION.
- REMOVE KEY.
- DO NOT WEAR LOOSE CLOTHING. REMOVE JEWELRY SUCH AS RINGS, WATCHES, CHAINS, ETC. BEFORE SERVICING VEHICLE.
- PUT F&R SWITCH IN NEUTRAL.
- **DISCONNECT BATTERIES** AS SHOWN IN FIGURE 17-1, PAGE 17-2.
- FOLLOW ALL PROCEDURES EXACTLY AS STATED.

### **DANGER**

- **TURN KEY SWITCH TO OFF AND REMOVE KEY, PUT THE F&R SWITCH IN NEUTRAL, AND DISCONNECT THE BATTERY CABLES AS SHOWN IN FIGURE 17-1, PAGE 17-2. FAILURE TO DO THIS MAY CAUSE THE VEHICLE TO RUN OVER YOU, RESULTING IN SEVERE INJURY OR DEATH!**

## Testing the Reverse Buzzer Circuit:

1. Disconnect the red/white wire from F&R limit switch No. 2 and connect the black probe of a multi-meter (set to volts) to the wire. Place the red probe of the multi-meter on the positive post of battery No. 1. The multi-meter should show battery voltage. If it doesn't, replace the red/white wire.
2. Disconnect both wires from F&R limit switch No. 2 and place the probes of a continuity tester on the wire terminals of the limit switch. With the limit switch lever up (open circuit), the tester should **not** be illuminated. With the limit switch lever down (closed circuit), the tester should be illuminated. If this is not the case, replace the limit switch.
3. Disconnect the batteries (**Figure 17-1, Page 17-2**) and discharge the speed controller (**See WARNING box on Page 17-25**).

### Testing the Reverse Buzzer, Continued:

4. Remove center dash.
  - 4.1. Remove the plastic cap covering the screw on each side of the center dash.
  - 4.2. Loosen (but do not remove) the screw on each side of the center dash panel.
  - 4.3. Insert screwdriver at top center of center dash between dash and cowl brace. Gently pry center dash out slightly from under edge of cowl brace.
  - 4.4. Pull center dash out approximately one inch from the frame and then bend the top right corner of the center dash panel inward while pulling the top of the panel out and down.

#### NOTE

- BENDING THE TOP RIGHT CORNER OF THE CENTER DASH INWARD WHILE REMOVING IT WILL PREVENT THE CONTACTS ON THE REAR OF THE KEY SWITCH FROM TOUCHING THE METAL FRAME AROUND THE DASH.

5. Slide center dash panel up the steering column by snapping out the top and then rotating the panel out and up. There is sufficient slack in the wiring to allow for this.
6. Disconnect the orange wire from the reverse buzzer and also from F&R limit switch No. 2. Connect the red probe of a continuity tester to the orange wire at the F&R end, and connect the black probe to the orange wire at the reverse buzzer end. The continuity tester should illuminate. If it doesn't, replace the orange wire.
7. Disconnect the red wire from the reverse buzzer. Connect the red probe of a continuity tester to the red wire and connect the black probe to the large stud (with No. 6 red wire attached) on the solenoid. If the tester does not illuminate, replace the red wire. If the tester does illuminate, replace the buzzer.

### Removing the reverse buzzer:

1. Disconnect the batteries (**Figure 17-1, Page 17-2**) and discharge the speed controller (**See WARNING box on Page 17-25**).
2. Remove center dash.
  - 2.1. Remove the plastic cap covering the screw on each side of the center dash.
  - 2.2. Loosen (but do not remove) the screw on each side of the center dash panel.
  - 2.3. Insert screwdriver at top center of center dash between dash and front body brace. Gently pry center dash out slightly from under edge of cowl brace.
  - 2.4. Pull center dash out approximately one inch from the frame and then bend the top right corner of the center dash panel inward while pulling the top of the panel out and down.

#### NOTE

- BENDING THE TOP RIGHT CORNER OF THE CENTER DASH INWARD WHILE REMOVING IT WILL PREVENT THE CONTACTS ON THE REAR OF THE KEY SWITCH FROM TOUCHING THE METAL FRAME AROUND THE DASH.

3. Slide center dash panel up the steering column by snapping out the top and then rotating the panel out and up. There is sufficient slack in the wiring to allow for this.
4. Disconnect the No. 18 red and orange wire from reverse buzzer.
5. Remove the two screws from the reverse buzzer.
6. Remove the reverse buzzer from the center dash panel.

### Installing the reverse buzzer:

Install the reverse buzzer in the reverse order of removal.

## THE SOLENOID

---

The solenoid is located on the passenger's side fender well behind the battery compartment. The solenoid has two sets of posts; two 5/16 inch posts (power contact posts) and two small No. 10 posts (activating coil posts).

### **WARNING**

- **WHEN MAKING ELECTRICAL TESTS OR REPAIRS, ALWAYS:**
- WEAR SAFETY GLASSES OR APPROVED EYE PROTECTION.
- REMOVE KEY.
- DO NOT WEAR LOOSE CLOTHING. REMOVE JEWELRY SUCH AS RINGS, WATCHES, CHAINS, ETC. BEFORE SERVICING VEHICLE.
- PUT F&R SWITCH IN NEUTRAL.
- **DISCONNECT BATTERIES** AS SHOWN IN FIGURE 17-1, PAGE 17-2.
- FOLLOW ALL PROCEDURES EXACTLY AS STATED.

### **DANGER**

- **TURN KEY SWITCH TO OFF AND REMOVE KEY, PUT THE F&R SWITCH IN NEUTRAL, AND DISCONNECT THE BATTERY CABLES AS SHOWN IN FIGURE 17-1, PAGE 17-2. FAILURE TO DO THIS MAY CAUSE THE VEHICLE TO RUN OVER YOU, RESULTING IN SEVERE INJURY OR DEATH!**

#### **Testing the solenoid:**

See Test Procedure 7, Page 17-16.

#### **Removing the solenoid:**

1. Disconnect batteries (**Figure 17-1, Page 17-2**).
2. Discharge the controller (**See instructions in Warning Box on Page 17-25**).

### **WARNING**

- FAILURE TO DISCHARGE THE CONTROLLER COULD RESULT IN A SHORT SHOULD THE WRENCH OR RATCHET TOUCH THE LARGE POST DURING REMOVAL OR INSTALLATION OF THE RESISTOR OR DIODE ASSEMBLY.

3. Disconnect all wires from solenoid. Remove resistor assembly and diode assembly.

#### **Installing the solenoid:**

1. Install the solenoid to the mounting plate and torque to 66 in.lbs. (7.5 N-m). The solenoid does not have to be oriented in any particular manner.
2. Install wires as shown in wiring diagram (**Figure 17-2, Page 17-3, or Figure 17-3, Page 17-4**).
3. Install diode and resistor as shown in wiring diagram (**Figure 17-2 or 17-3**).

#### **THE DIODE - (SOLENOID)**

A diode is placed across the solenoid activating coil to allow the field to collapse and prevent limit switch failures. If limit switches are failing, the diode should be checked for correct orientation.

## DANGER

- **TURN KEY SWITCH TO OFF AND REMOVE KEY, PUT THE F&R SWITCH IN NEUTRAL, AND DISCONNECT THE BATTERY CABLES AS SHOWN IN FIGURE 17-1, PAGE 17-2. FAILURE TO DO THIS MAY CAUSE THE VEHICLE TO RUN OVER YOU, RESULTING IN SEVERE INJURY OR DEATH!**

## WARNING

- **WHEN MAKING ELECTRICAL TESTS OR REPAIRS, ALWAYS:**
- WEAR SAFETY GLASSES OR APPROVED EYE PROTECTION.
- REMOVE KEY.
- DO NOT WEAR LOOSE CLOTHING. REMOVE JEWELRY SUCH AS RINGS, WATCHES, CHAINS, ETC. BEFORE SERVICING VEHICLE.
- PUT F&R SWITCH IN NEUTRAL.
- **DISCONNECT BATTERIES AS SHOWN IN FIGURE 17-1, PAGE 17-2.**
- FOLLOW ALL PROCEDURES EXACTLY AS STATED.

### Removing the diode:

The diode assembly is connected between the two small No. 10 posts (activating coil posts) on the solenoid.

1. Disconnect batteries (**Figure 17-1, Page 17-2**).
2. Discharge the controller (**See instructions in Warning Box on Page 17-25**).

## WARNING

- FAILURE TO DISCHARGE THE CONTROLLER COULD RESULT IN A SHORT SHOULD THE WRENCH OR RATCHET TOUCH THE LARGE POST DURING REMOVAL OR INSTALLATION OF THE RESISTOR OR DIODE ASSEMBLY.

3. Remove the two nuts attaching diode assembly to the solenoid.
4. Remove diode assembly.

### Testing the diode:

1. Using a VOM, check for continuity between both diode terminals. Reverse the tester leads and again check for continuity.
2. A diode is designed to conduct current in one direction only. If a diode shows continuity in both directions or does not show continuity in either direction, replace diode assembly.

### Installing the diode:

1. Install diode assembly to small No. 10 solenoid studs.
2. Insure that the direction of the diode is correct (**Figure 17-2, Page 17-3, or Figure 17-3, Page 17-4**).
3. Install remaining wires to studs as shown in **Figure 17-2 or 17-3**. Install red insulated terminal on the No. 10 stud (No. 18 red wire also attaches to this stud).
4. Install and tighten two No.10 nuts to posts. Torque to 17-20 in.lbs. (2.0/2.3 N-m).

### RESISTOR - (SOLENOID)

A 250 ohms resistor is placed across the contacts to keep the capacitors in the controller charged. This reduces arcing on the contacts of the solenoid. Whenever a solenoid fails, this 250 ohms resistor should be checked.

### Removing the resistor:

1. Disconnect batteries (Figure 17-1, Page 17-2).
2. Discharge the controller (See instructions in Warning Box on Page 17-25).

#### **WARNING**

- FAILURE TO DISCHARGE THE CONTROLLER COULD RESULT IN A SHORT SHOULD THE WRENCH OR RATCHET TOUCH THE LARGE POST DURING REMOVAL OR INSTALLATION OF THE RESISTOR OR DIODE ASSEMBLY.

3. Remove the two large nuts that attach the resistor to the solenoid.
4. Remove the resistor from the solenoid.

### Testing the resistor:

1. Using a VOM, check for continuity between both resistor terminals. Reverse the tester leads and again check for continuity.
2. If measurement is different from approximately 250 ohms, replace the resistor.

### Installing the resistor:

1. Install in reverse order of removal (See Figure 17-2, Page 17-3, or Figure 17-3, Page 17-4 for proper wiring).

## ON BOARD COMPUTER (OBC)

---

### Testing

See Test Procedure 11, Page 17-20.

#### **WARNING**

- **WHEN MAKING ELECTRICAL TESTS OR REPAIRS, ALWAYS:**
- WEAR SAFETY GLASSES OR APPROVED EYE PROTECTION.
- REMOVE KEY.
- DO NOT WEAR LOOSE CLOTHING. REMOVE JEWELRY SUCH AS RINGS, WATCHES, CHAINS, ETC. BEFORE SERVICING VEHICLE.
- PUT F&R SWITCH IN NEUTRAL.
- **DISCONNECT BATTERIES** AS SHOWN IN FIGURE 17-1, PAGE 17-2.
- FOLLOW ALL PROCEDURES EXACTLY AS STATED.

### Removing the on-board computer:

1. Disconnect batteries (Figure 17-1, Page 17-2).
2. Discharge the controller (See instructions in Warning Box on Page 17-25).

#### **WARNING**

- FAILURE TO DISCHARGE THE CONTROLLER COULD RESULT IN A SHORT SHOULD THE WRENCH OR RATCHET TOUCH THE LARGE POST ON THE SOLENOID.

### Removing The On-board Computer, Continued:

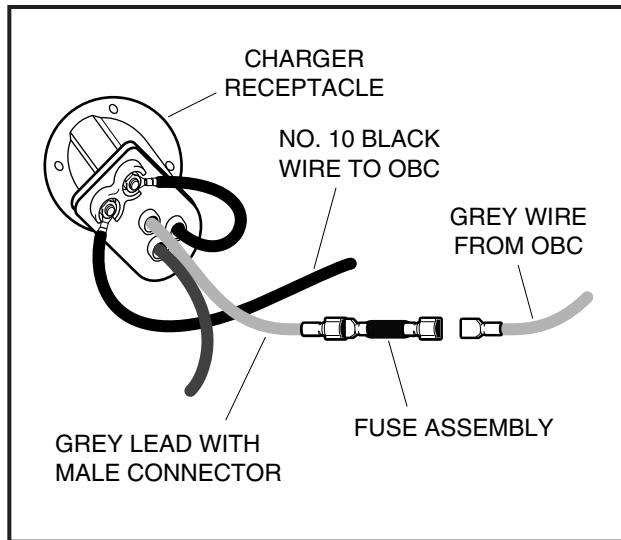

FIGURE 17-15

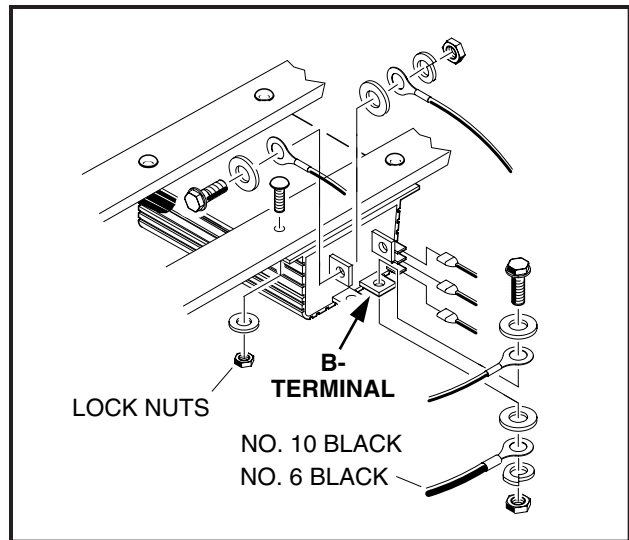

FIGURE 17-16

3. Disconnect the No. 10 black wire (to the OBC) from the back of the charger receptacle (**Figure 17-15**).
4. Disconnect the gray wire (from the OBC) at the sense lead fuse, leaving the sense lead fuse connected to the grey lead from the charger receptacle (**Figure 17-15**).
5. Remove the No. 18 red and yellow wires on the solenoid.
6. Disconnect the No. 6 and No. 10 black wires from B- of the controller (**Figure 17-16**).
7. Disconnect the No. 18 brown wire from OBC.
8. Remove the two 7/16 lock nuts holding the OBC.
9. Remove the OBC from the car.

### Installing the on-board computer:

Install the OBC in reverse order of removal.

## SOLID STATE SPEED CONTROLLER

### Testing the speed controller:

See Test Procedure 10, Page 17-18.

### Removing the speed controller:

1. Disconnect the batteries (**Figure 17-1, Page 17-2**).
2. Discharge the controller (**See instructions in Warning Box on Page 17-25**).

### **⚠ WARNING**

- FAILURE TO DISCHARGE THE CONTROLLER COULD RESULT IN A SHORT SHOULD THE WRENCH OR RATCHET TOUCH THE LARGE POST ON THE SOLENOID.

3. Remove all the No. 6 wires connected to the controller (**Figure 17-16**).



4. Unplug the three No. 18 wires plugged into the controller (**Figure 17-16**).
5. Remove the four 7/16 lock nuts holding the controller (**Figure 17-16**).
6. Remove the controller from the vehicle.

### Installing the Solid State Speed Controller:

Install in reverse order of disassembly.

## CHARGER RECEPTACLE

### Testing the Charger Receptacle:

See Section 19, See Test Procedure 1, Page 19-13

### Removing the Receptacle (Figure 17-17):

1. Remove the No. 10 red wire (4) from the positive post of battery No. 1, and then pull the No. 10 red wire to the receptacle (2) (**Figure 17-17**).
2. Locate the 1/4" "quick disconnect" terminal on the No. 10 grey wire from the charger receptacle. Disconnect the No. 10 grey wire (3) at this terminal, leaving the sense lead fuse (1) attached to the grey wire from the on-board computer (**Figure 17-17**).
3. Remove the No. 10 black wire (5) from the charger receptacle using a ratchet and a 3/8" socket.
4. Use a phillips screwdriver to remove the four screws (9) from the bezel (7), and the three screws (12) from receptacle (2).

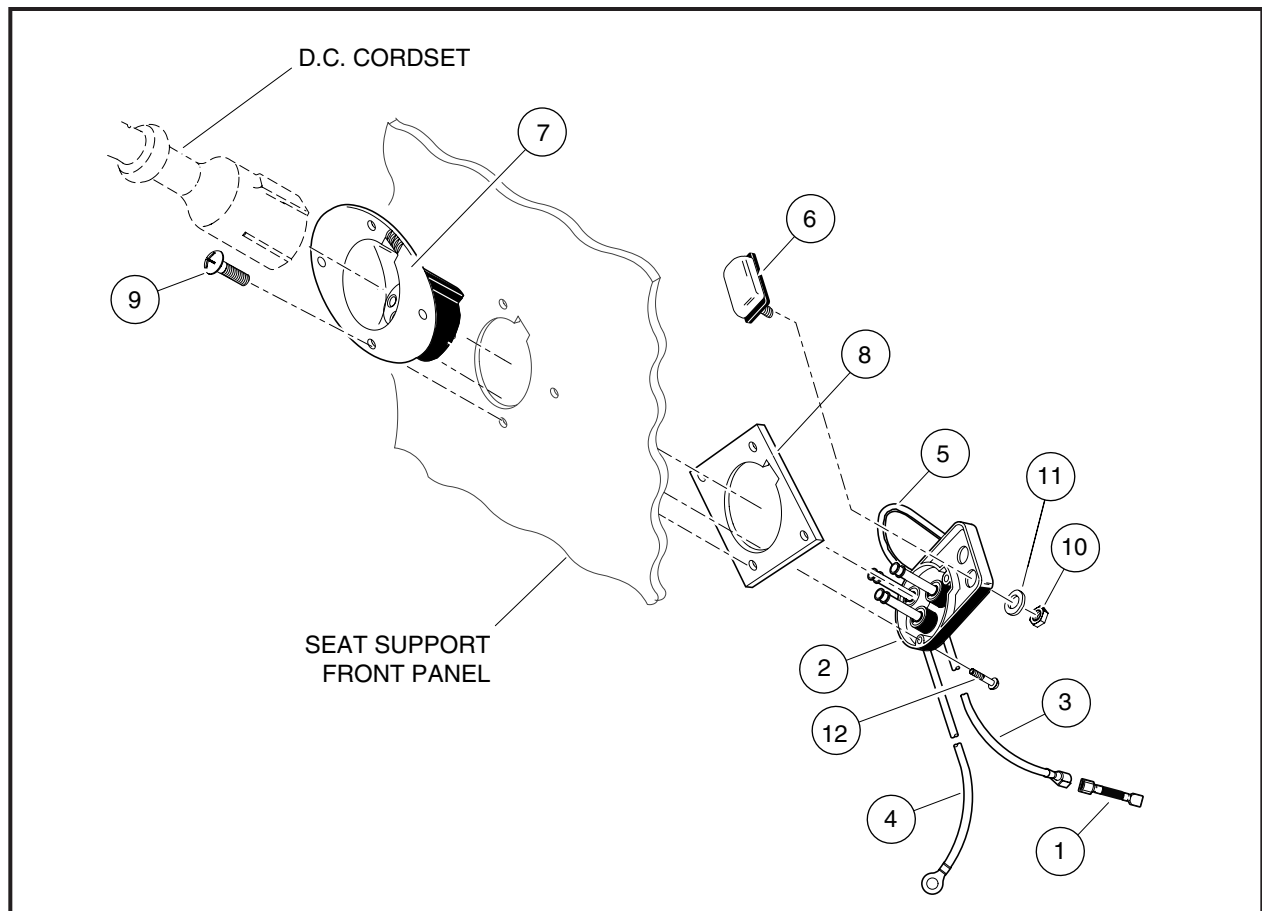

FIGURE 17-17

### Installing a New Receptacle (Figure 17-17, Page 17-35):

1. Install the bezel (7) with four screws (9) through the bezel and body and into the receptacle backing plate (8). Torque screws to 9-13 in.lbs. (1.0/1.5 N-m).
2. Thread the No. 10 red wire (4) through the tie wraps on the front body support and attach the connector to the positive post of battery No. 1 (See Figure 19-7, Page 19-14).
3. Attach the #10 black wire from the on-board computer to the fuse assembly using a ratchet and a 3/8" socket (See Figure 19-2, Page 19-3).
4. Connect 1/4" connector on the No. 10 grey wire (3) from the charger receptacle to the No. 18 grey wire from the on-board computer. Make sure that the fuse is installed between the No. 10 grey wire from the receptacle and the No. 18 grey wire from the on-board computer (See Figure 19-2, Page 19-3).

#### **WARNING**

- DO NOT BY-PASS SENSE LEAD FUSE.

### RECEPTACLE FUSE LINK

If the fuse link has blown, the vehicle will not charge until it has been replaced. The fuse link is located behind the charger receptacle in the battery compartment. See the circuit diagram (Figure 19-2, Page 19-3).

#### **WARNING**

- THE RECEPTACLE FUSE LINK SHOULD NEVER BLOW UNDER NORMAL OPERATING CONDITIONS. IF THE FUSE HAS BLOWN, DETERMINE THE SOURCE OF THE ELECTRICAL PROBLEM AND CORRECT IT BEFORE REPLACING FUSE.
- **WHEN MAKING ELECTRICAL TESTS OR REPAIRS, ALWAYS:**
  - WEAR SAFETY GLASSES OR APPROVED EYE PROTECTION.
  - REMOVE KEY.
  - DO NOT WEAR LOOSE CLOTHING. REMOVE JEWELRY SUCH AS RINGS, WATCHES, CHAINS, ETC. BEFORE SERVICING VEHICLE.
  - PUT F&R SWITCH IN NEUTRAL.
- **DISCONNECT BATTERIES** AS SHOWN IN FIGURE 17-1, PAGE 17-2, AND THEN DISCHARGE THE CONTROLLER AS INSTRUCTED IN THE WARNING ON PAGE 17-22 OF THIS MANUAL.
- FOLLOW ALL PROCEDURES EXACTLY AS STATED.

### Removal of receptacle fuse link (Figure 17-17, Page 17-35):

1. Remove the fuse link assembly and lens (6) from the charger receptacle (2) by removing the two nuts (10) and washers also used to secure the No. 10 black wire from the computer and the No. 10 black wire (5) to the receptacle.
2. Remove the fuse link (6) from the charger receptacle.

### Installation of new receptacle fuse link (Figure 17-17, Page 17-35):

1. Insert the two fuse link mounting studs into the mounting holes in the charger receptacle.
2. Place two flat washers (11) on the studs.
3. Place the two No. 10 black wires in their original positions on the fuse link mounting studs.
4. Install the nuts (10) on the fuse link mounting studs and torque to 20-25 in.lbs. (2.3/32.8 N-m).

## **WARNING**

- **WHEN MAKING ELECTRICAL TESTS OR REPAIRS, ALWAYS:**
- WEAR SAFETY GLASSES OR APPROVED EYE PROTECTION.
- REMOVE KEY.
- DO NOT WEAR LOOSE CLOTHING. REMOVE JEWELRY SUCH AS RINGS, WATCHES, CHAINS, ETC. BEFORE SERVICING VEHICLE.
- PUT F&R SWITCH IN NEUTRAL.
- **DISCONNECT BATTERIES** AS SHOWN IN FIGURE 17-1, PAGE 17-2.
- FOLLOW ALL PROCEDURES EXACTLY AS STATED.

## **DANGER**

- **TURN KEY SWITCH TO OFF AND REMOVE KEY, PUT THE F&R SWITCH IN NEUTRAL, AND DISCONNECT THE BATTERY CABLES AS SHOWN IN FIGURE 17-1, PAGE 17-2. FAILURE TO DO THIS MAY CAUSE THE VEHICLE TO RUN OVER YOU, RESULTING IN SEVERE INJURY OR DEATH!**

## **CONTINUOUSLY VARIABLE POTENTIOMETER**

---

### **Testing the Continuously Variable Potentiometer:**

See Test Procedure 9, Page 17-17.

### **Removing the Continuously Variable Potentiometer (Figure 17-18, Page 17-38):**

1. Disconnect batteries (Figure 17-1, Page 17-2).
2. Discharge the controller (See instructions in Warning Box on Page 17-25).

## **WARNING**

- FAILURE TO DISCHARGE THE CONTROLLER COULD RESULT IN A SHORT SHOULD A WRENCH OR RATCHET TOUCH THE LARGE POST ON THE SOLENOID.

3. Remove center dash.
  - 3.1. Remove the plastic cap covering the screw on each side of the center dash.
  - 3.2. Loosen (but do not remove) the screw on each side of the center dash panel.
  - 3.3. Insert screwdriver at top center of center dash between dash and front body brace. Gently pry center dash out slightly from under edge of front body brace.
  - 3.4. Pull center dash out approximately one inch from the frame and then bend the top right corner of the center dash panel inward while pulling the top of the panel out and down.

## **NOTE**

- BENDING THE TOP RIGHT CORNER OF THE CENTER DASH INWARD WHILE REMOVING IT WILL PREVENT THE CONTACTS ON THE REAR OF THE KEY SWITCH FROM SNAGGING THE METAL FRAME AROUND THE DASH.

## Removing the Continuously Variable Potentiometer, Continued:

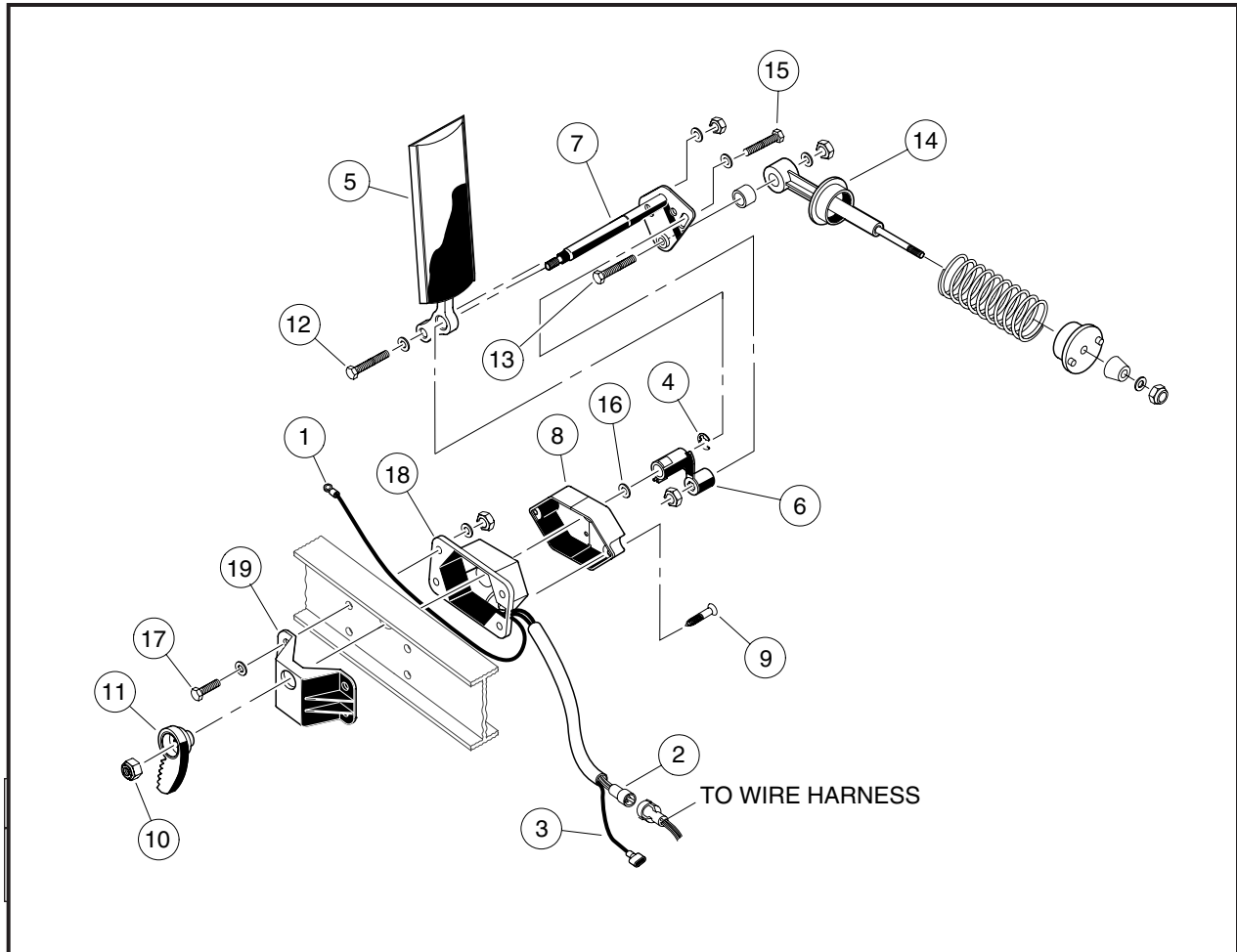

**FIGURE 17-18**

- Slide the center dash panel up the steering column by snapping out the top and then rotating the panel out and up. There is sufficient slack in the wiring to allow for this.
- Disconnect the No. 18 blue wire (1) from the key switch.
- Unplug the three pin connector (2) which connects the potentiometer to the wire harness (**Figure 17-18**).
- Unplug the No. 18 green/white wire (3) from F&R limit switch No.1.
- Remove the crescent retaining ring (4), which is located between the accelerator pedal (5) and the actuator lever (6), from the pivot rod (7).
- Remove the potentiometer housing cover (8) by removing the two No. 4 screws (9) (**Figure 17-18**).
- Remove the 3/8 lock nut (10) on the ratchet (11) (**Figure 17-18**).
- Remove the 5/16 bolt (12), two washers, and nut attaching the accelerator pedal (5) to the accelerator pivot rod (7) (**Figure 17-18**).
- Remove the 1/4 bolt (13) and nut attaching the spring retainer (14) to the accelerator pivot rod.

### **NOTE**

- WHEN INSTALLING THE CENTER DASH, MAKE SURE TO BEND THE TOP RIGHT CORNER OF THE DASH PANEL INWARD TO GIVE THE WIRES AND TERMINALS CLEARANCE.

13. Remove the 1/4 bolt (15), washer, and nut attaching the actuator lever (6) to the accelerator pivot rod (**Figure 17-18**).
14. Remove the pivot rod.

### NOTE

- THERE IS A NYLON WASHER (16) BETWEEN THE ACTUATOR LEVER AND THE POTENTIOMETER HOUSING.

15. Remove the four 1/4 inch bolts (17), washers, and nuts attaching the potentiometer housing (18) and the pivot rod support (19) to the frame (**Figure 17-18**).
16. Remove the potentiometer housing and pivot rod support from the I-Beam.

### Installing the Continuously Variable Potentiometer (Figure 17-18):

1. Position the potentiometer housing (18) and pivot rod support (19) on the frame and install the four 1/4 bolts (17) with washers and nuts.
2. Install the pivot rod (7), accelerator pedal (5), actuator lever (6), and the nylon washer (16) into the potentiometer housing.

### NOTE

- DO NOT TIGHTEN BOLTS AT THIS TIME.

3. Now tighten the four 1/4 inch potentiometer housing mounting bolts (17) to between 70 and 80 in.lbs (8.0/9.0 N-m).

### NOTE

- MAKE SURE THAT THE ACTUATOR LEVER PIN IS INSERTED INTO THE POTENTIOMETER LEVER.

4. Install the spring retainer (14) on the pivot rod.
5. Position the ratchet (11) on the end of the pivot rod so that there is approximately an .030 to .090 inch gap between the pawl and the ratchet teeth (this can be verified with a feeler gauge).
6. Install and tighten nut (10) to between 16 and 20 ft.lbs. (21.7/27.1 N-m).
7. Install the crescent retaining ring (4) between the accelerator pedal (5) and the actuator lever (6) on the pivot rod (7).
8. Route and connect the No. 18 blue wire (1) to the key switch.
9. Install the center dash panel in reverse order of removal.

### NOTE

- WHEN INSTALLING THE CENTER DASH, MAKE SURE TO BEND THE TOP RIGHT CORNER OF THE DASH PANEL INWARD TO GIVE THE WIRES AND TERMINALS CLEARANCE.

10. Connect the three pin connector (2) from potentiometer to the lead from the wire harness.
11. Plug the No. 18 gage green/white wire (3) to F&R limit switch No. 1.
12. Adjust the pedal group per Pedal Group Adjustment Instructions (**Field Service Bulletin No. 95-5, included at the end of this publication**).

## MULTI-STEP POTENTIOMETER

---

### WARNING

- **WHEN MAKING ELECTRICAL TESTS OR REPAIRS, ALWAYS:**
- WEAR SAFETY GLASSES OR APPROVED EYE PROTECTION.
- REMOVE KEY.
- DO NOT WEAR LOOSE CLOTHING. REMOVE JEWELRY SUCH AS RINGS, WATCHES, CHAINS, ETC. BEFORE SERVICING VEHICLE.
- PUT F&R SWITCH IN NEUTRAL.
- **DISCONNECT BATTERIES** AS SHOWN IN FIGURE 17-1, PAGE 17-2.
- FOLLOW ALL PROCEDURES EXACTLY AS STATED.

### DANGER

- **TURN KEY SWITCH TO OFF AND REMOVE KEY, PUT THE F&R SWITCH IN NEUTRAL, AND DISCONNECT THE BATTERY CABLES AS SHOWN IN FIGURE 17-1, PAGE 17-2. FAILURE TO DO THIS MAY CAUSE THE VEHICLE TO RUN OVER YOU, RESULTING IN SEVERE INJURY OR DEATH!**

### Testing the Multi-step Potentiometer:

See Test Procedure 8, Page 17-17.

### Removing the Multi-step Potentiometer:

1. Disconnect the batteries (**Figure 17-1, Page 17-2**).
2. Remove the battery wire connecting batteries No. 5 and No. 6 and the battery wire connecting batteries No. 5 and No. 4 (**Figure 17-1, Page 17-2**).
3. Using a 1/2 inch wrench, remove the hold-down brackets from the No. 5 and No. 6 batteries and then remove the No. 5 and No. 6 batteries from the vehicle (**Figure 17-1, Page 17-2**).
4. Slide back the ball stud retainer on the potentiometer end of the accelerator rod (1) and disconnect the accelerator rod from the multi-step potentiometer (**Figure 17-19**).
5. Disconnect the No. 18 black (2), white (3), and blue (4) wires from the multi-step potentiometer (**Figure 17-19**).
6. Disconnect the No. 18 green/white wire (5) at the F&R limit switch No. 1 (**Figure 17-19**).
7. Using a 3/8 inch wrench, remove the nuts (6) and lock washers (7) from underneath the I-Beam and lift the multi-step potentiometer assembly from the frame. Remove the shim plate (8) (**Figure 17-19**).

### Installing the Multi-step Potentiometer (**Figure 17-19**):

1. Position the shim plate (8) on the frame I-Beam with the mounting holes properly aligned.
2. Use a flat-blade screwdriver to push the locking tabs out of the tab retainers, and remove the potentiometer cover (9).
3. Position the potentiometer on the shim plate and frame with mounting holes aligned and insert the mounting bolts (10) through the potentiometer base, the shim plate, and the frame as shown.
4. Hold the mounting bolts in place while installing the lock washers (7) and nuts (6). Tighten nut to between 18 and 22 in.lbs. (2.0/2.5 N-m).

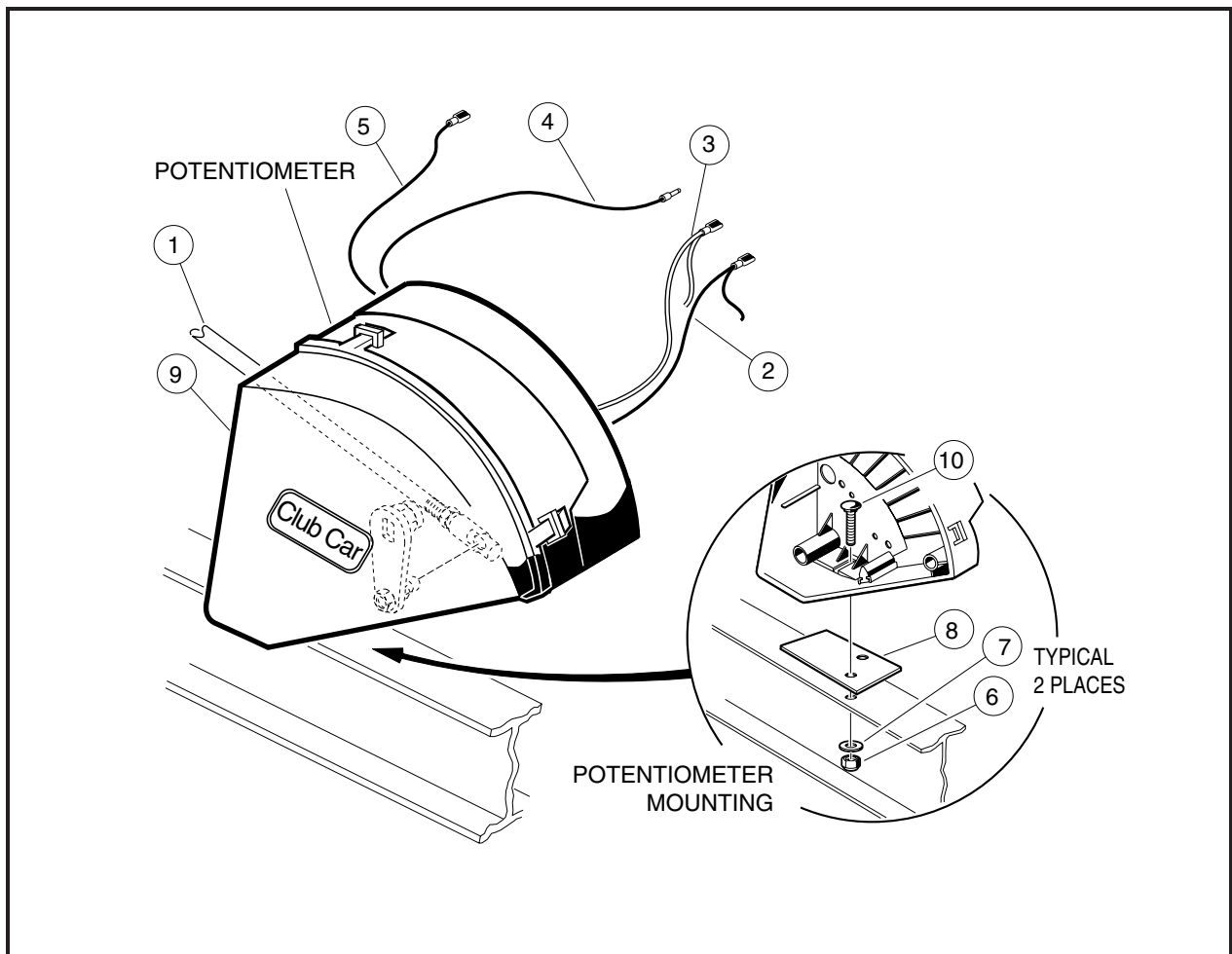

**FIGURE 17-19**

5. Connect the No. 18 green/white wire to F&R limit switch No. 1. Connect the No. 18 black (2), white (3), and blue (4) wires to the multi-step potentiometer.
6. Connect the accelerator rod (1) to the potentiometer.
7. Install and connect the No. 5 and No. 6 batteries.





## SECTION 18 - BATTERIES

### WARNING

- ONLY TRAINED TECHNICIANS SHOULD REPAIR OR SERVICE THIS VEHICLE. ANYONE DOING EVEN SIMPLE REPAIRS OR SERVICE SHOULD HAVE SOME KNOWLEDGE AND EXPERIENCE IN GENERAL ELECTRICAL REPAIR. FOLLOW ALL PROCEDURES EXACTLY AND HEED ALL WARNINGS STATED IN THIS MANUAL.
- ALWAYS WEAR SAFETY GLASSES OR APPROVED EYE PROTECTION WHILE SERVICING VEHICLE. WEAR A FULL FACE SHIELD WHEN WORKING WITH BATTERIES.
- TURN KEY SWITCH OFF, PLACE FORWARD AND REVERSE LEVER IN THE NEUTRAL POSITION, AND REMOVE KEY PRIOR TO SERVICING.
- DO NOT WEAR LOOSE CLOTHING. REMOVE JEWELRY SUCH AS RINGS, WATCHES, CHAINS, ETC. BEFORE SERVICING VEHICLE.
- ALWAYS USE INSULATED TOOLS WHEN WORKING NEAR BATTERIES OR ELECTRICAL CONNECTIONS.
- TO AVOID UNINTENTIONAL STARTING OF THE VEHICLE, **DISCONNECT BATTERIES AND DISCHARGE THE CONTROLLER** AS DESCRIBED IN THE **WARNING** ON PAGE 18-4.

### DANGER

- WEAR A FULL FACE SHIELD WHEN WORKING AROUND BATTERIES BECAUSE OF THE DANGER OF AN EXPLODING BATTERY.
- **BATTERY - EXPLOSIVE GASES - DO NOT SMOKE!** KEEP SPARKS, FLAMES, CIGARETTES AWAY. TOOLS, WIRES AND METAL OBJECTS CAN CAUSE SPARKS WHEN “SHORTED” ACROSS A BATTERY. INSULATED TOOLS SHOULD BE USED. EXTREME CARE SHOULD BE TAKEN WHEN DISCONNECTING OR RECONNECTING BATTERIES. WHEN WIRES ARE DISCONNECTED, BE SURE TO KEEP THEM AWAY FROM BATTERY POSTS AND OTHER WIRES. VENTILATE WHEN CHARGING OR USING IN AN ENCLOSED SPACE TO PREVENT EXPLOSIVE GAS BUILD-UP.
- **POISON - CONTAINS ACID - CAUSES SEVERE BURNS - AVOID CONTACT WITH SKIN, EYES OR CLOTHING!**

#### **BATTERY ACID ANTIDOTES:**

EXTERNAL: FLUSH WITH WATER. **CALL PHYSICIAN IMMEDIATELY!**

INTERNAL: DRINK LARGE QUANTITIES OF MILK OR WATER. FOLLOW WITH MILK OF MAGNESIA OR VEGETABLE OIL. **CALL PHYSICIAN IMMEDIATELY!**

EYES: FLUSH WITH WATER FOR 15 MINUTES. **CALL PHYSICIAN IMMEDIATELY!**

## GENERAL INFORMATION

The batteries supplied with a golf car are different from those supplied with an automobile. The outward appearance of these two batteries is similar, but the operating characteristics are very different. The golf car battery is known as a “deep cycle” battery, and the automotive battery is known as a “starting, lighting and ignition” (SLI) battery. They should never be substituted for one another.

An automotive battery has to deliver high cranking currents of 300-400 amperes at a sufficient voltage for several seconds and maintain an accessory load of 10-25 amperes in stop and go driving. The energy removed from an automotive battery is immediately replaced by the alternator or generator of the car. As a result, the automotive battery operates at 90 to 100% of full charge at all times.

### General Information Continued:

The batteries supplied with an electric vehicle must supply 100% of the energy required to move the vehicle. These batteries therefore receive deep discharge down to 30% to 40% of their full charge capacity. Then they must be recharged, hence their name "deep cycle." The average amperage draw is considered to be 75 amps on a 36 volt car, and 56 amps on a 48 volt car, although it varies greatly depending on the vehicle and how it is operated. Golf car batteries are specifically designed to handle this type of service.

The rechargeable lead-acid battery is a device for turning chemical energy into electrical energy and vice versa. The main active elements within a battery are the positive plates, the negative plates and the electrolyte (sulfuric acid). Another very important element (but inactive) is the separator. The separator does exactly what its name implies - it keeps the material of the positive and negative plates from touching each other and creating electrical shorts. It must be porous enough to allow charged ions to pass through between the positive and the negative plates, but never allow the two materials to contact each other.

Whenever two unlike metals are immersed in an acid solution, an electric current is generated.

In a "deep cycle" battery, the negative plates contain lead (Pb) and the positive plates contain lead dioxide (PbO<sub>2</sub>). These plates are immersed in a sulfuric acid solution (H<sub>2</sub>SO<sub>4</sub>) (**Figure 18-1**).

During discharge, the chemical reaction inside the battery causes the sulfate (SO<sub>4</sub>) to break away from the H<sub>2</sub> (**Figure 18-2**).

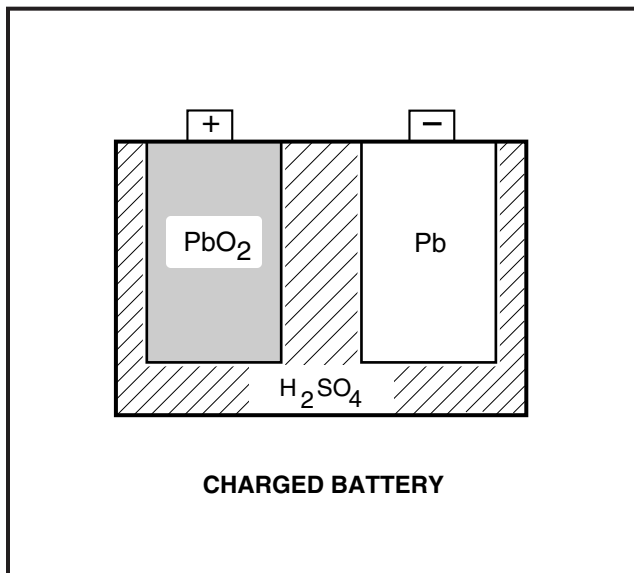

FIGURE 18-1

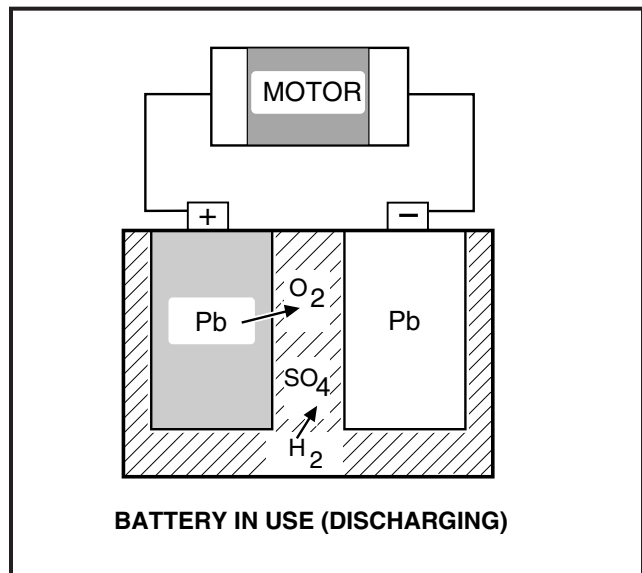

FIGURE 18-2

The (SO<sub>4</sub>) combines with the lead (Pb) on both plates, forming lead sulphate (PbSO<sub>4</sub>). The oxygen (O<sub>2</sub>) from the positive plates combines with the hydrogen (H) from the electrolyte to form water (H<sub>2</sub>O) (**Figure 18-3**).

The result is two similar metals, lead sulphate (PbSO<sub>4</sub>), immersed in water (H<sub>2</sub>O). This, of course, will not generate electricity. This battery is discharged.

When a discharged battery is connected to a charger, the process is reversed. The sulfate (SO<sub>4</sub>) is forced from the plates back into the electrolyte to make sulfuric acid (H<sub>2</sub>SO<sub>4</sub>). The oxygen returns to the positive plate to make lead dioxide (PbO<sub>2</sub>) (**Figure 18-4**).

The result is a charged battery that is again capable of generating electricity (**Figure 18-1**).

In a deep cycle battery, the grids are heavy and the paste much denser to accommodate the deep cycle in electric vehicle application. Some manufacturers have to use an even denser paste to avoid the shedding of the paste, especially from the positive grid, that occurs to a greater or lesser extent in all batteries as they age.

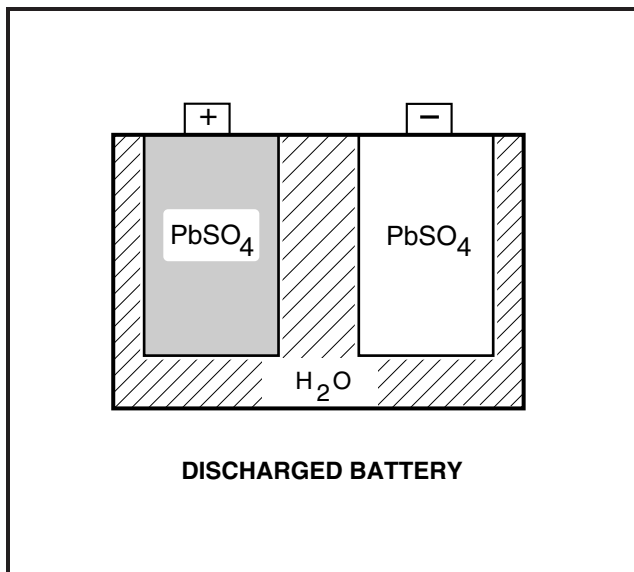

FIGURE 18-3

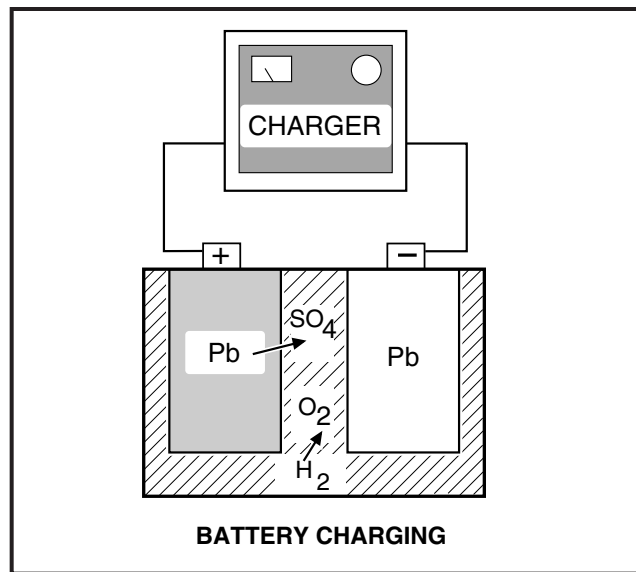

FIGURE 18-4

## COMMON MISCONCEPTIONS ABOUT BATTERIES

This chart cannot and does not describe all problems which may be encountered with batteries, but it does identify some of the common misconceptions and problems.

PROBLEM	MISCONCEPTION AND REALITY
1. Deep Discharge	"This car can handle another 9 holes; it has gone only 36 holes today." This statement is wrong! Avoid deep discharge of batteries whenever possible. See Battery Charging, Page 18-7.
2. Early Excessive Discharging	"These are new batteries. They can handle 45 holes." Wrong again! New batteries do not reach their full capacity until they have been used and recharged 20 to 50 times.
3. Mineral Content	"Tap water will do for our batteries." It might be OK, but have it checked first. See Battery Care, Page 18-5.
4. Self Discharge	"That dirt and corrosion on the battery won't hurt anything." Wrong. It may provide a path for current to flow and allow the batteries to self discharge.
5. Over Watering	"Add water to the level indicator tonight so we won't have to do it in the morning." Water should be added after charging. See Battery Care, Page 18-5.
6. Under Watering	"Checking the water takes too much time; we'll check it next month." Insufficient watering can ruin batteries. Water level should be checked weekly. See Battery Care, Page 18-5.
7. Vibration Damage	"Tighten that battery hold-down as tight as you can." Battery hold-downs should be tightened to specification. Hold-downs that are too tight or too loose can cause battery damage. See Battery Care, Page 18-5.

## REPLACING BATTERIES

### DANGER

- WEAR A FULL FACE SHIELD WHEN WORKING AROUND BATTERIES BECAUSE OF THE DANGER OF AN EXPLODING BATTERY.
- **BATTERY - EXPLOSIVE GASES - DO NOT SMOKE!** KEEP SPARKS, FLAMES, CIGARETTES AWAY. TOOLS, WIRES AND METAL OBJECTS CAN CAUSE SPARKS WHEN “SHORTED” ACROSS A BATTERY. INSULATED TOOLS SHOULD BE USED. EXTREME CARE SHOULD BE TAKEN WHEN DISCONNECTING OR RECONNECTING BATTERIES. WHEN WIRES ARE DISCONNECTED, BE SURE TO KEEP THEM AWAY FROM BATTERY POSTS AND OTHER WIRES. VENTILATE WHEN CHARGING OR USING IN AN ENCLOSED SPACE TO PREVENT EXPLOSIVE GAS BUILD-UP.
- **POISON - CONTAINS ACID - CAUSES SEVERE BURNS - AVOID CONTACT WITH SKIN, EYES OR CLOTHING!**

#### **BATTERY ACID ANTIDOTES:**

EXTERNAL: FLUSH WITH WATER. **CALL PHYSICIAN IMMEDIATELY!**

INTERNAL: DRINK LARGE QUANTITIES OF MILK OR WATER. FOLLOW WITH MILK OF MAGNESIA OR VEGETABLE OIL. **CALL PHYSICIAN IMMEDIATELY!**

EYES: FLUSH WITH WATER FOR 15 MINUTES. **CALL PHYSICIAN IMMEDIATELY!**

### WARNING

- TO AVOID UNINTENTIONAL STARTING OF THE VEHICLE, DISCONNECT THE BATTERIES AS SHOWN IN FIGURE 17-1 (PAGE 17-2), AND THEN DISCHARGE THE CONTROLLER AS FOLLOWS:
  - TURN THE KEY SWITCH TO “ON” AND PLACE THE FORWARD AND REVERSE LEVER IN THE REVERSE POSITION.
  - SLOWLY DEPRESS THE ACCELERATOR PEDAL AND KEEP IT DEPRESSED UNTIL THE REVERSE WARNING BUZZER CAN NO LONGER BE HEARD. WHEN THE BUZZER STOPS SOUNDING, THE CONTROLLER IS DISCHARGED.
- TO PREVENT ELECTROLYTE LEAKAGE FROM THE BATTERY VENTS, BATTERIES MUST BE KEPT IN AN UPRIGHT POSITION. TIPPING A BATTERY BEYOND A 45° ANGLE IN AN ANY DIRECTION CAN ALLOW A SMALL AMOUNT OF ELECTROLYTE TO LEAK OUT THE VENT HOLE. DO NOT EXCEED THIS 45° ANGLE WHEN LIFTING, CARRYING, OR INSTALLING BATTERIES. BATTERY ACID CAN CAUSE SEVERE PERSONAL INJURY TO SKIN OR EYES, AND CAN DAMAGE CLOTHING.

1. Before removing batteries, note the orientation of the batteries and the connecting wires. First, disconnect the batteries and discharge the controller as described in the WARNING above. Then remove remaining wires and batteries.
  - **See Figure 18-5 For 36 volt V-Glide Vehicle battery wiring.**
  - **See Figure 18-6 For PowerDrive System 48 Vehicle battery wiring.**
2. Visually inspect the new batteries for any damage that may have occurred in transit.
3. If the old battery wires are going to be reused, inspect them for broken or frayed wires, damaged terminals, or worn insulation. Remove any corrosion on the connectors. One cup of bicarbonate of soda (baking soda) in a gallon of water and a wire brush do an excellent job of neutralizing and removing the corrosion. Be careful not to allow this baking soda solution to enter the battery.

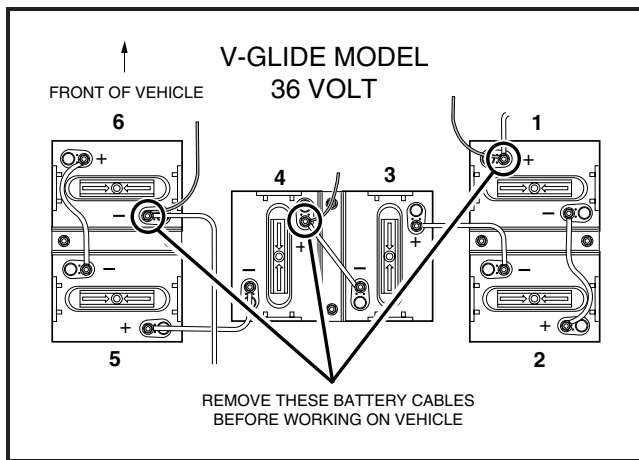

**FIGURE 18-5**

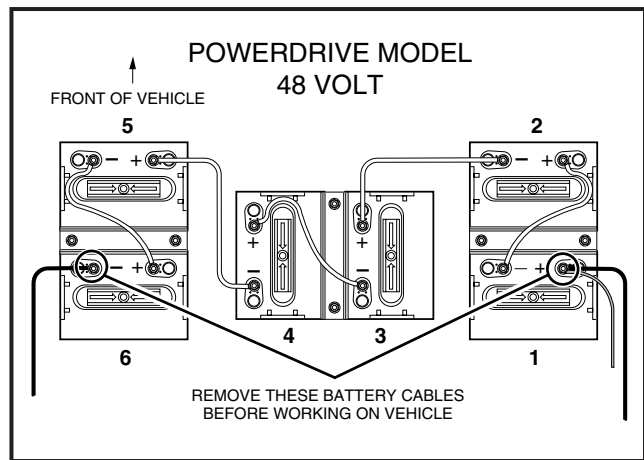

**FIGURE 18-6**

4. Check and clean the battery rack and hold-downs. The nuts and bolts on the hold-downs may corrode. It is therefore advised that they be cleaned periodically and replaced as necessary.
5. Install the batteries in the proper orientation (**Figure 18-5 or Figure 18-6**). Install the battery hold-downs. The hold-downs should be tight enough so the batteries do not move while the car is in motion, but not so tight as to crack or buckle the battery case. Torque to 15-25 in.lbs. (1.7/2.8 N-m), alternating between hold-downs.
6. Install wires in proper sequence (**Figure 18-5 or Figure 18-6**). Install black wire to negative post of battery No. 6 last. Make sure all connections are tight. Torque to 90-100 in.lbs. (10/11.3 N-m). Coat all terminals with Battery Protector Spray (CLUB CAR Part No.1014305) to minimize future corrosion.
  - **V-Glide 36 volt only** - Be sure wire on lower left of F&R switch goes to battery No.1 positive post. Wire on lower right of F&R switch goes to battery No. 4 positive post. This applies to vehicles equipped with resistor coil type speed controls only.
7. Give the batteries a full charge prior to sending them out on the golf course. This ensures that all the batteries are fully charged and the cells are equalized prior to use.

## BATTERY CARE

### Preventive Maintenance

To keep batteries in good operating condition, follow these steps on a regular basis.

1. Any corrosion build-up on or around batteries should be removed immediately. Terminal connections should be clean and tight. Any frayed or worn wires should be replaced. After all cables have been connected, coat all terminals with Battery Protector Spray (CLUB CAR Part No.1014305) to ward off future corrosion.
2. Batteries should be kept clean and dry to prevent self discharge. Any dirt, grime or acid spillage should be removed. Wash batteries with a bristle brush using water and bicarbonate of soda (baking soda-1 cup per gallon). Rinse with water. Do not allow solution to enter battery through the vent cap holes (**See Self Discharge, Page 18-6**).
3. Maintain proper water level (**See Water Level, Figure 18-7, Page 18-6**).
4. Batteries should be properly charged every day they are used. Check the batteries periodically to see that they are in a full state of charge (**See Battery Charging, Page 18-7**).
5. Keep hold-downs tight (**See Vibration Damage, Page 18-7**).

## Self Discharge

Dirty batteries can provide a path for a small current draw that can slowly discharge batteries, thus wasting valuable energy. To prevent self discharge, batteries should always be kept clean.

Hot weather also has an effect on a battery's self discharge rate. The higher the temperature, the quicker a set of batteries will discharge. In hotter climates, therefore, batteries should be checked more often. When storing batteries, keep in a cool place (**See Battery Storage, page 18-17**).

## Water Level

### **⚠ CAUTION**

- DO NOT ALLOW BATTERY ACID FROM BATTERY CAPS OR HYDROMETER TO DRIP ONTO THE FRONT OR REAR BODY. BATTERY ACID WILL CAUSE PERMANENT BLEMISHES. WASH OFF IMMEDIATELY.

Add water only after charging unless the water is below the level of the plates. Filling a battery before charging will result in overfilling, because the electrolyte level will rise during charging and some of the electrolyte may bubble out of the cap. This reduces its capacity and corrodes the metal parts around it.

The water level should be checked weekly to be sure water is at its proper level (**Figure 18-7**). Never allow the water level to fall below the tops of the plates because this will cause the exposed part of the plate to become permanently inactive. Check the water level more frequently in hot weather or when batteries become old.

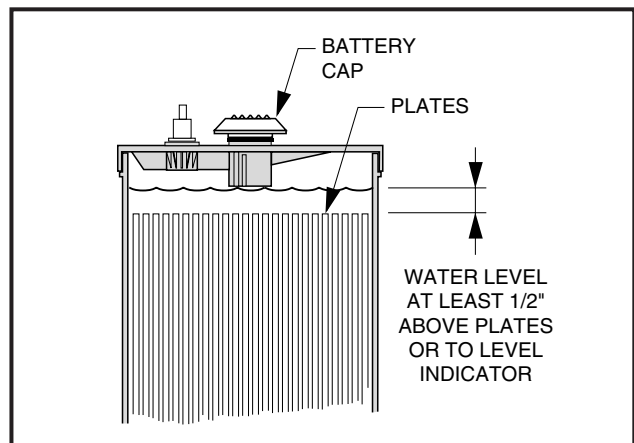

**FIGURE 18-7**

## Mineral Content

For the longest battery life, distilled water should be used in batteries. However, if tap water is going to be used, be sure the mineral contents are below these levels:

<b>IMPURITY</b>	<b>ALLOWABLE CONTENT IN PARTS PER MILLION</b>
Suspended Matter	Trace
Total Solids	100.0
Calcium and Magnesium Oxides	40.0
Iron	5.0
Ammonia	8.0
Organic Matter	50.0
Nitrates	10.0
Nitrites	5.0
Chloride	5.0
<b>Contact your local water department for this analysis</b>	



## **Vibration Damage**

The battery hold-downs should always be tight enough to keep the battery from bouncing. Battery life may be severely shortened if the battery hold-downs are too loose. Excessive vibration causes the plates to shed prematurely and shortens the life of the battery. It may also cause acid to leak out of the vent caps and corrosion to build up on surrounding metal parts. The acid which is lost reduces the capacity of the battery and cannot be replaced.

Battery hold-downs should NOT be so tight as to crack or buckle the battery case. This may cause leaks which would dry up a cell or cause internal shorts (**See Replacing Batteries, Page 18-4**).

## **BATTERY CHARGING**

---

### **General Information**

The charger supplied with the CLUB CAR DS Electric Vehicle solves the most common problems in charging. Undercharging and overcharging are prevented provided the charger is allowed to shut off by itself. Also, all cells are automatically given an equalization charge at low current, which prolongs battery life. Batteries should never be left in a discharged state, as this too affects the internal components and can reduce the capacity of the battery. The batteries should be charged every day they are used, even if only for ten minutes or after nine holes. However, the batteries should not be charged if they have not been used. When running 36 holes per day, it is wise to put the cars on charge after the first 18 holes. Even if the charger is only on for an hour or two, it will prevent the batteries from being discharged deeply. If a charger is still on in the morning and it becomes necessary to send the car out before charging is complete, be sure the car gets a catch-up charge between rounds. The following night this car must get a full charge.

### **Charger Doesn't Shut Off**

This may be due to one of the following factors:

1. New batteries
2. Hard use - more than 36 holes per day
3. Cold temperatures
4. Short charging times - in late at night, out early in the morning

A catch-up charge may be necessary when these conditions are present. On a rainy day or an off day, when all or some of the cars do not go out, check the batteries in the cars for state of charge. Any batteries with a specific gravity lower than 1.250 need a catch-up charge. If the problem continues after a catch-up charge has been performed, refer to the charger section of the service manual.

### **Deep Discharge**

Never discharge a vehicle's batteries to the point that the vehicle will no longer run. This will shorten the cycle life of the batteries considerably, and may permanently damage the batteries. It is possible that the batteries will not accept a recharge if they are completely discharged. The deeper the discharge, the harder it is on the batteries. For this reason, it is recommended that cars be charged between rounds. Placing the batteries on charge between rounds reduces the depth of discharge and prolongs battery life.

### **Early Excessive Discharging**

When golf car batteries are new, they do not reach their full capacity until they have been used and recharged 20 to 50 times. If they are excessively discharged early in their life, their effective service life will be shortened. It is advisable to limit the use of any car with new batteries to 18 holes per day for at least the first 4 weeks and then gradually increase their range.

### **Incoming AC Service**

Insure that the incoming AC line service is sufficient. If circuit breakers are tripping, fuses blow during the night or the charger does not give the required starting rate when perfectly good batteries are put on charge, an AC line problem exists. The electrical service to your car storage facility should be sufficient to deliver 115

### Incoming AC Service Continued:

volts (minimum 105 volts, maximum 128 volts) and 10.7 amps per charger with all the chargers turned on. If not, consult your local power company or electrical contractor.

### Fleet Rotation

Rotate your cars. Put a different set of cars out first each morning. It is very hard on batteries if the last cars in at night are the first ones out in the morning and also are required to go 36 holes. Spread the workload evenly, giving all cars the same amount of play. This will keep your fleet in balance and will not overwork certain sets of batteries.

#### NOTE

- WHEN A FLEET OF POWERDRIVE SYSTEM 48 VEHICLES IS BEING ROTATED, THE CLUB CAR CDM (COMMUNICATION DISPLAY MODULE) CAN BE A TREMENDOUSLY HELPFUL SERVICE TOOL. BY MONITORING THE VALUE OF FUNCTION 3 WITH THE CDM, IT CAN BE DETERMINED WHICH CARS SHOULD TO BE USED (SEE PAGE 17-21). HOUR METERS CAN BE USED TO MONITOR THE USAGE OF 36 VOLT VEHICLES.

### Numbering Cars and Chargers

Return the cars to the same charger each night if possible. If the cars are put in a storage facility at random and a car dies on the course and testing shows the batteries are good, you know you may have a bad charger - you just don't know where. Numbering the cars and the chargers and returning each car to its designated charger each night can be a great aid in troubleshooting a problem.

## BATTERY TESTING

Four tests have been developed to test a set of batteries that has not lived up to its expected performance. Each test becomes progressively more thorough and time consuming. It is therefore suggested to begin with the first test and follow through with the other tests until the problem has been found as outlined in the battery troubleshooting chart (**Figure 18-8**).

### DANGER

- WEAR A FULL FACE SHIELD WHEN WORKING AROUND BATTERIES BECAUSE OF THE DANGER OF AN EXPLODING BATTERY.
- **BATTERY - EXPLOSIVE GASES - DO NOT SMOKE!** KEEP SPARKS, FLAMES, CIGARETTES AWAY. TOOLS, WIRES AND METAL OBJECTS CAN CAUSE SPARKS WHEN "SHORTED" ACROSS A BATTERY. INSULATED TOOLS SHOULD BE USED. EXTREME CARE SHOULD BE TAKEN WHEN DISCONNECTING OR RECONNECTING BATTERIES. WHEN WIRES ARE DISCONNECTED, BE SURE TO KEEP THEM AWAY FROM BATTERY POSTS AND OTHER WIRES. VENTILATE WHEN CHARGING OR USING IN AN ENCLOSED SPACE TO PREVENT EXPLOSIVE GAS BUILD-UP.
- **POISON - CONTAINS ACID - CAUSES SEVERE BURNS!** - AVOID CONTACT WITH SKIN, EYES OR CLOTHING.

#### **BATTERY ACID ANTIDOTES:**

EXTERNAL: FLUSH WITH WATER. **CALL PHYSICIAN IMMEDIATELY.**

INTERNAL: DRINK LARGE QUANTITIES OF MILK OR WATER. FOLLOW WITH MILK OF MAGNESIA OR VEGETABLE OIL. **CALL PHYSICIAN IMMEDIATELY.**

EYES: FLUSH WITH WATER FOR 15 MINUTES. **CALL PHYSICIAN IMMEDIATELY.**

## BATTERY TROUBLESHOOTING CHART

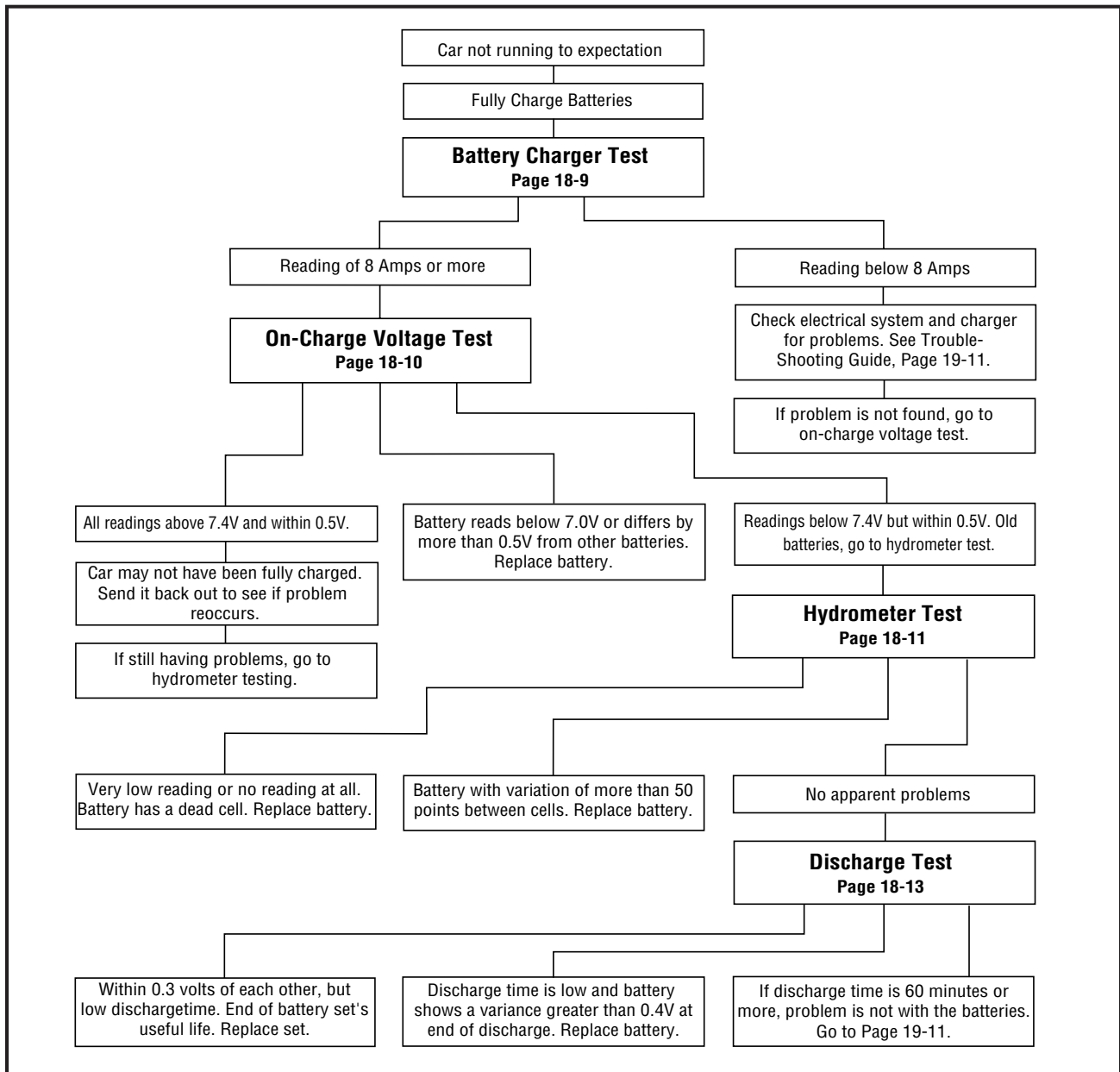

FIGURE 18-8

### **WARNING**

- TURN KEY SWITCH OFF, PLACE FORWARD AND REVERSE LEVER IN THE NEUTRAL POSITION, AND REMOVE KEY PRIOR TO SERVICING.

### BATTERY CHARGER TEST

The easiest way to monitor the condition of your batteries is simply to observe the reading of your battery charger ammeter at the end of the charge cycle. After a full charge, disconnect and reconnect the charger DC plug (**PowerDrive System 48 vehicle only** - Wait 20 to 30 seconds before reinserting the DC charger plug. Failure to do so will not allow the charger to turn on again). The ammeter needle will jump to 15 amps or more and then taper into the 5 to 8 amp area within 10 to 20 minutes, indicating good, fully charged batteries.

### Battery Charger Test Continued:

Continued poor performance may indicate a problem in the golf car electrical system, brakes or battery charger. If the problem is not found in the golf car or charging system, proceed to the on-charge voltage test. Batteries that remain at 8 amps or higher should be tested further using the on-charge voltage test.

## DANGER

- WEAR A FULL FACE SHIELD WHEN WORKING AROUND BATTERIES BECAUSE OF THE DANGER OF AN EXPLODING BATTERY.
- **BATTERY - EXPLOSIVE GASES - DO NOT SMOKE!** KEEP SPARKS, FLAMES, CIGARETTES AWAY. TOOLS, WIRES AND METAL OBJECTS CAN CAUSE SPARKS WHEN “SHORTED” ACROSS A BATTERY. INSULATED TOOLS SHOULD BE USED. EXTREME CARE SHOULD BE TAKEN WHEN DISCONNECTING OR RECONNECTING BATTERIES. WHEN WIRES ARE DISCONNECTED, BE SURE TO KEEP THEM AWAY FROM BATTERY POSTS AND OTHER WIRES. VENTILATE WHEN CHARGING OR USING IN AN ENCLOSED SPACE TO PREVENT EXPLOSIVE GAS BUILD-UP.
- **POISON - CONTAINS ACID - CAUSES SEVERE BURNS!** - AVOID CONTACT WITH SKIN, EYES OR CLOTHING.

### BATTERY ACID ANTIDOTES:

EXTERNAL: FLUSH WITH WATER. **CALL PHYSICIAN IMMEDIATELY.**

INTERNAL: DRINK LARGE QUANTITIES OF MILK OR WATER. FOLLOW WITH MILK OF MAGNESIA OR VEGETABLE OIL. **CALL PHYSICIAN IMMEDIATELY.**

EYES: FLUSH WITH WATER FOR 15 MINUTES. **CALL PHYSICIAN IMMEDIATELY.**

## WARNING

- TURN KEY SWITCH OFF, PLACE FORWARD AND REVERSE LEVER IN THE NEUTRAL POSITION, AND REMOVE KEY PRIOR TO SERVICING.

### On-Charge Voltage Test (36 volt V-Glide)

When the batteries are fully charged, disconnect and reconnect the charger DC plug to restart the charger. After 20 minutes, record the voltage of the battery set as well as the individual batteries, using the VOM, (CLUB CAR part No.1011480). Set the meter on 50 VDC. Place the red (+) probe at the positive terminal and the black (-) probe at the negative terminal of each battery. Record reading. The on-charge voltage for the set should read between 42.0 volts and 47.4 volts depending on the make, size and age of the battery being tested. If individual batteries read between 7.4 and 7.9 volts, the car may not have been fully charged when the problem occurred. Send the car back out to see if the problem reoccurs. If the problem persists, go to the hydrometer test. If any battery reads below 7.0 volts or differs by more than 0.5 volts from the other batteries, have it replaced. If readings are below 7.4 volts but within 0.5 volts of each other, the batteries are old. Batteries may have enough capacity left to last several more months. Go to hydrometer test (**See Trouble-Shooting Chart, Figure 18-8, and examples on following pages**).

### On-Charge Voltage Test (PowerDrive System 48)

When the batteries are fully charged, disconnect the charger DC plug. Wait 20 to 30 seconds and reconnect the DC plug to restart the charger. After 5 minutes, record the voltage of the battery set as well as the indi-

vidual batteries, using the VOM (CLUB CAR Part No.1011480). Set the meter on 100 VDC. Place the red (+) probe at the positive post of the battery No. 1 and the the black (-) probe at the negative post of battery No. 6 (**Figure 18-6**). Record reading. Then set VOM on 50 VDC and place the red (+) probe at the positive terminal and the black (-) probe at the negative terminal of each battery. Record reading. The on-charge voltage for the set should read between 56.0 volts and 63.0 volts depending on the age of the battery being tested. If individual batteries read between 9.8 and 10.5 volts, the car may not have been fully charged when the problem occurred. Send the car back out to see if the problem reoccurs. If the problem persists, go to hydrometer test. If any battery reads below 9.3 volts or differs by more than 0.7 volts from the other batteries, have it replaced. If readings are below 9.8 volts but within 0.7 volts of each other, the batteries are old. Batteries may have enough capacity left to last several more months. Go to hydrometer test (**See Troubleshooting Chart, Figure 18-8, and examples on following pages**).

## HYDROMETER TEST

A hydrometer measures the specific gravity. The higher the specific gravity, the higher the state of charge of the batteries. A fully charged battery should read between 1.250 and 1.280 at 80°F. Never add acid to batteries to obtain a higher specific gravity.

### Performing the Hydrometer Test

1. Be sure that the batteries have sufficient water to cover the plates by approximately 1/2 inch and are fully charged prior to beginning the test. If water must be added, recharge the batteries before performing the hydrometer test.
2. Remove the vent cap.
3. Using a battery thermometer (CLUB CAR part No.1011767), record the electrolyte temperature of the No. 2 cell.
4. Squeeze the rubber bulb of the hydrometer and insert into the cell. Slowly release the bulb, drawing electrolyte up into the glass tube of the hydrometer.
5. When the float rises off the bottom, adjust the electrolyte level so that the float rides free of the bottom but does not strike the top of the glass tube. Remove the hydrometer from the cell and release the pressure from the bulb.
6. Hold the hydrometer vertically, insuring that the float is not contacting the sides of the barrel. Hold the hydrometer at eye level and read the scale at the level of electrolyte (**Figure 18-9**).
7. Record the reading.
8. Return the electrolyte to the cell from which it was taken. Replace vent cap.
9. Repeat steps 2-8 on all cells.

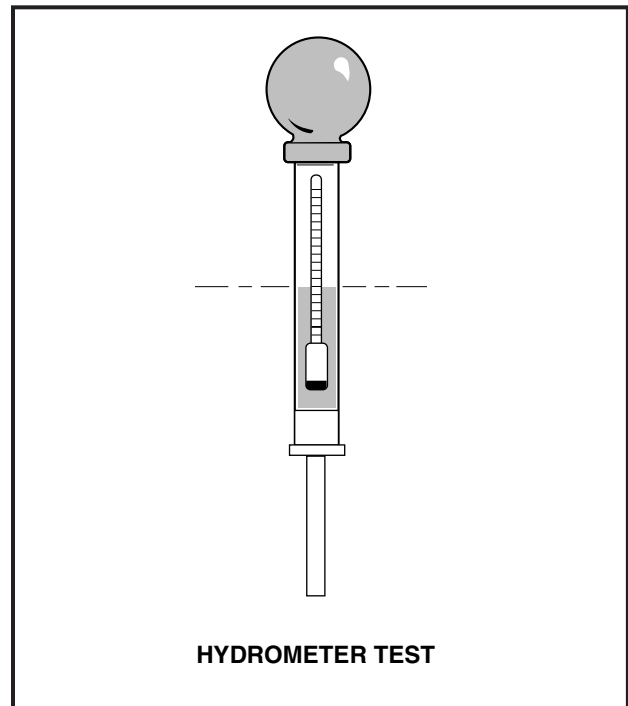

**FIGURE 18-9**

### Hydrometer Calibration

Most hydrometers are calibrated to read correctly at 80°F. The readings obtained as described above must be corrected for temperature. For each 10°F above 80°F, add .004 to the reading. For each 10°F below 80°F, subtract .004 from the reading.

## Interpreting the Results of the Hydrometer Test

The approximate state of charge can be determined from the following table:

SPECIFIC GRAVITY AT 80°	STATE OF CHARGE
1.250 - 1.280	100%
1.220 - 1.240	75%
1.190 - 1.210	50%
1.160 - 1.180	25%

If the difference between the cells is .020 or more, the low cell should be suspected. It may require a catch-up charge or it may be a weak cell. When the variations between cells reach .050 or more, the battery with the low cell should be replaced.

### 36 volt V-Glide Vehicle

CAR NO.	BATTERY NO.	ELECTROLYTE TEMP.	CORRECTION FACTOR	CORRECTED SPECIFIC GRAVITY			REQUIRED ACTION
				POSITIVE CELL	CENTER CELL	NEGATIVE CELL	
12	1	20°F	-.024	1.275-.024=1.251	1.280-.024=1.256	1.280-.024=1.256	Good Battery-Fully Charged
35	6	90°F	+.004	1.155+.004=1.159	1.165+.004=1.169	1.160+.004=1.164	Discharged Battery-Recharge
54	3	50°F	-.012	1.260-.012=1.248	1.200-.012=1.188	1.270-.012=1.258	Bad Center Cell
69	5	80°F	.000	1.250-0=1.250	1.255-0=1.255	1.230-0=1.230	Weak Negative Cell-Catch-up Charge
38	2	100°F	+.008	1.200+.008=1.208	1.180+.008=1.188	1.170+.008=1.178	Discharged Battery-Recharge and Recheck
22	4	80°F	.000	1.240-0=1.240	1.245-0=1.245	Float Does Not Rise	Negative Cell Dead-Replace Battery

### Powerdrive System 48 Vehicle

CAR NO.	BATTERY NO.	ELECTROLYTE TEMP.	CORRECTION FACTOR	CORRECTED SPECIFIC GRAVITY				REQUIRED ACTION
				CELL 1	CELL 2	CELL 3	CELL 4	
12	1	20°F	-.024	1.275-.024=1.251	1.280-.024=1.256	1.280-.024=1.256	1.280-.024=1.256	Good Battery-Fully Charged
35	6	90°F	+.004	1.155+.004=1.159	1.165+.004=1.169	1.160+.004=1.164	1.165+.004=1.169	Discharged Battery-Recharge
54	3	50°F	-.012	1.260-.012=1.248	1.200-.012=1.188	1.270-.012=1.258	1.270-.012=1.258	Bad No. 2 Cell
69	5	80°F	.000	1.250-0=1.250	1.255-0=1.255	1.230-0=1.230	1.250-0=1.250	Weak No. 3 Cell-Catch-up Charge
38	2	100°F	+.008	1.200+.008=1.208	1.180+.008=1.188	1.170+.008=1.178	1.180+.008=1.188	Discharged Battery-Recharge and Recheck
22	4	80°F	.000	1.240-0=1.240	1.245-0=1.245	Float Does Not Rise	1.250-0=1.250	No. 3 Cell Dead-Replace Battery

## ⚠ DANGER

- WEAR A FULL FACE SHIELD WHEN WORKING AROUND BATTERIES BECAUSE OF THE DANGER OF AN EXPLODING BATTERY.
- **BATTERY - EXPLOSIVE GASES - DO NOT SMOKE!** KEEP SPARKS, FLAMES, CIGARETTES AWAY. TOOLS, WIRES AND METAL OBJECTS CAN CAUSE SPARKS WHEN “SHORTED” ACROSS A BATTERY. INSULATED TOOLS SHOULD BE USED. EXTREME CARE SHOULD BE TAKEN WHEN DISCONNECTING OR RECONNECTING BATTERIES. WHEN WIRES ARE DISCONNECTED, BE SURE TO KEEP THEM AWAY FROM BATTERY POSTS AND OTHER WIRES. VENTILATE WHEN CHARGING OR USING IN AN ENCLOSED SPACE TO PREVENT EXPLOSIVE GAS BUILD-UP.
- **POISON - CONTAINS ACID - CAUSES SEVERE BURNS!** - AVOID CONTACT WITH SKIN, EYES OR CLOTHING.

### BATTERY ACID ANTIDOTES:

EXTERNAL: FLUSH WITH WATER. **CALL PHYSICIAN IMMEDIATELY.**

INTERNAL: DRINK LARGE QUANTITIES OF MILK OR WATER. FOLLOW WITH MILK OF MAGNESIA OR VEGETABLE OIL. **CALL PHYSICIAN IMMEDIATELY.**

EYES: FLUSH WITH WATER FOR 15 MINUTES. **CALL PHYSICIAN IMMEDIATELY.**

## ⚠ WARNING

- TURN KEY SWITCH OFF, PLACE FORWARD AND REVERSE LEVER IN THE NEUTRAL POSITION, AND REMOVE KEY PRIOR TO SERVICING.

## DISCHARGE TEST

If the previous tests have failed to discover the problem with a set of batteries, conduct a discharge test. The discharge test comes closest to simulating the actual golf car operating conditions by continuously drawing amps from the batteries until voltage drops to 1.75 per cell.

- **V-Glide 36 volt vehicle - draws 75 amps until batteries drop to 31.5 volts.**
- **PowerDrive System 48 vehicle - draws 56 amps until batteries drop to 42.0 volts.**

The discharge test is the hardest test on the batteries and the most time-consuming to perform. Use the battery discharge tester (CLUB CAR Part No.1018319-01). This discharge tester can be used on both 36 volt V-Glide and 48 volt Powerdrive vehicles.

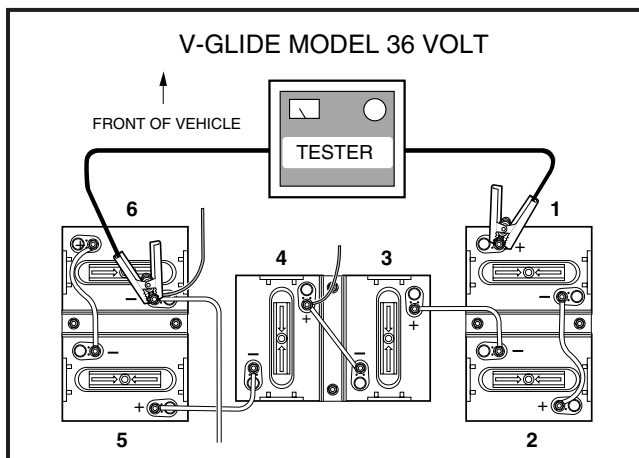

FIGURE 18-10

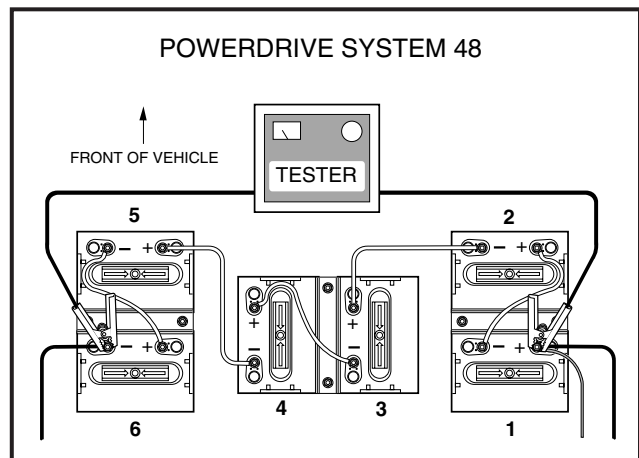

FIGURE 18-11



## DANGER

- WEAR A FULL FACE SHIELD WHEN WORKING AROUND BATTERIES BECAUSE OF THE DANGER OF AN EXPLODING BATTERY.
- BATTERY - EXPLOSIVE GASES - DO NOT SMOKE! KEEP SPARKS, FLAMES, CIGARETTES AWAY. TOOLS, WIRES AND METAL OBJECTS CAN CAUSE SPARKS WHEN "SHORTED" ACROSS A BATTERY. INSULATED TOOLS SHOULD BE USED. EXTREME CARE SHOULD BE TAKEN WHEN DISCONNECTING OR RECONNECTING BATTERIES. WHEN WIRES ARE DISCONNECTED, BE SURE TO KEEP THEM AWAY FROM BATTERY POSTS AND OTHER WIRES. VENTILATE WHEN CHARGING OR USING IN AN ENCLOSED SPACE TO PREVENT EXPLOSIVE GAS BUILD-UP.
- POISON - CONTAINS ACID - CAUSES SEVERE BURNS! - AVOID CONTACT WITH SKIN, EYES OR CLOTHING.

### **BATTERY ACID ANTIDOTES:**

EXTERNAL: FLUSH WITH WATER. **CALL PHYSICIAN IMMEDIATELY.**

INTERNAL: DRINK LARGE QUANTITIES OF MILK OR WATER. FOLLOW WITH MILK OF MAGNESIA OR VEGETABLE OIL. **CALL PHYSICIAN IMMEDIATELY.**

EYES: FLUSH WITH WATER FOR 15 MINUTES. **CALL PHYSICIAN IMMEDIATELY.**

## WARNING

- TURN KEY SWITCH OFF, PLACE FORWARD AND REVERSE LEVER IN THE NEUTRAL POSITION, AND REMOVE KEY PRIOR TO SERVICING.

### **Performing the Discharge Test**

1. Be sure that the batteries are fully charged and that the electrolyte level is correct in all cells.
2. Connect the tester leads to the positive (+) post of battery No.1 and negative (-) post of battery No. 6 **(See Figure 18-10 for V-Glide 36 volt vehicle. See Figure 18-11 for PowerDrive System 48 vehicle).**
3. Check and record the electrolyte temperature of the battery packs.
  - 36 volt V-Glide vehicle - check center cell of each battery.
  - PowerDrive System 48 vehicle - check cell No. 2 of each battery.
4. Reset discharge machine (or reset timer if using older discharge machine with 36 volt vehicle)
5. Turn the tester on.
6. When the batteries have been discharging for approximately 60 minutes, set the discharge machine to function 3 and check voltage of the battery set. Check battery set voltage every 10 minutes from this point through the rest of the test. As soon as the battery set voltage reaches .50 volts above shut-off point **(31.5 volts for V-Glide 36 volt vehicles, and 42.0 volts for PowerDrive System 48 vehicles)**, use a VOM to measure individual battery voltages. Measure and record the voltage of each battery to the nearest .01 volt.

### **NOTE**

- THE TESTER WILL SHUT OFF AUTOMATICALLY WHEN SHUT-OFF VOLTAGE IS REACHED.

## Interpreting Discharge Test Results

1. If discharge time is 60 minutes or higher, the problem is not with the batteries.
2. If discharge times are low, compare individual battery voltages recorded in step No. 6 above. If any battery shows a 0.4 volt or greater variance, the battery is bad or nearing the end of its useful life and should be discarded or grouped with other batteries at or around same voltage. The voltage of a bad battery will drop more rapidly near the end of the discharge than that of a good battery.

### V-Glide 36 volt Vehicle

BATTERY VOLTAGES						BATTERY CONDITION
1	2	3	4	5	6	
5.25	5.25	5.25	5.25	5.25	5.25	EXCELLENT
5.3	5.3	5.4	4.9	5.3	5.3	BATTERY NO.4 IS NEAR END OF USEFUL LIFE
5.4	5.4	5.0	5.5	4.7	5.5	BATTERIES NO.3 AND NO.5 ARE NEAR END OF USEFUL LIFE

### PowerDrive System 48 Vehicle

BATTERY VOLTAGES						BATTERY CONDITION
1	2	3	4	5	6	
7.00	7.00	7.00	7.00	7.00	7.00	EXCELLENT
7.07	7.07	7.22	6.50	7.07	7.07	BATTERY NO. 4 IS NEAR END OF USEFUL LIFE
7.20	7.20	6.67	7.33	6.27	7.33	BATTERIES NO. 3 AND NO. 5 ARE NEAR END OF USEFUL LIFE

3. If all the batteries are within 0.30 volts of each other, but the discharge time is low, the batteries are approaching the end of their life and the whole set will have to be replaced. In general, cars that discharge in less than 60 minutes at 78°F on the discharge test will not normally make 36 holes. However, discharge time is dependent on the electrolyte temperature. The table shown gives the discharge times at various temperatures of a set of batteries that delivers 62 minutes at 80°F.

ELECTROLYTE TEMP. °F	DISCHARGE TIME TO SHUT-OFF POINT	ELECTROLYTE TEMP. °F	DISCHARGE TIME TO SHUT-OFF POINT
40 - 49	40 Minutes	85 - 89	64 Minutes
50 - 59	45	89 - 99	66
60 - 64	50	100 - 109	68
65 - 69	54	110 - 119	70
70 - 74	57	120 - 129	72
75 - 79	60	130 - 150	74
80 - 84	62		

## Battery Troubleshooting Examples

A few examples of troubleshooting battery problems should clarify the procedure.

### Example 1

Car No. 68 was suspected of having a bad battery due to its performance. As a result, the battery charger test was performed. After a full charge, the battery charger ammeter read 8.0 amps. Next, the on-charge voltage test was performed and the following results were recorded:

#### V-Glide 36 volt Vehicle

BATTERY NO.	1	2	3	4	5	6
ON-CHARGE VOLTAGE	7.61	7.95	7.36*	7.62	7.92	7.96

#### PowerDrive System 48 Vehicle

BATTERY NO.	1	2	3	4	5	6
ON-CHARGE VOLTAGE	10.15	10.60	9.80*	10.16	10.56	10.61

\*Battery No. 3 appears to be suspect. Batteries No. 1 and No. 4 are also suspect. Next a hydrometer test should be conducted on all batteries.

Hydrometer test results were as follows:

#### V-Glide 36 volt Vehicle

BATTERY NO.	1	2	3	4	5	6
<b>SPECIFIC GRAVITY</b>						
POSITIVE POST CELL	1.200*	1.265	1.300	1.250	1.280	1.260
CENTER CELL	1.285	1.275	1.290	1.270	1.295	1.265
NEGATIVE POST CELL	1.275	1.270	1.285	1.265	1.275	1.275

#### PowerDrive System 48 Vehicle

BATTERY NO.	1	2	3	4	5	6
<b>SPECIFIC GRAVITY</b>						
CELL 1 (POSITIVE POST)	1.200*	1.265	1.300	1.250	1.280	1.260
CELL 2	1.285	1.275	1.290	1.270	1.295	1.265
CELL 3	1.265	1.270	1.275	1.265	1.280	1.275
CELL 4 (NEGATIVE POST)	1.275	1.270	1.285	1.265	1.275	1.275

\*After the hydrometer test, it appears that battery No. 1 is the problem.

### V-Glide 36 volt Vehicle

BATTERY NO.	1	2	3	4	5	6
DISCHARGE VOLTAGE	4.08*	5.50	5.80	5.36	5.57	5.56

### PowerDrive System 48 Vehicle

BATTERY NO.	1	2	3	4	5	6
DISCHARGE VOLTAGE	5.44*	7.33	7.73	7.15	7.43	7.41

\*After a discharge test which lasted 65 minutes, battery No. 1 is clearly shown to be the problem. Battery No. 4 should be watched a little more closely but appears to be okay. Battery No. 1 should be changed out with a battery that has about the same age and usage as the other batteries.

### Example 2

Car No. 70 was also suspected of having a bad battery due to its performance. The battery charger test showed 7.0 amps after a full charge. After confirming that there were no problems with the electrical system, charger or brakes, the on-charge voltage was recorded as follows:

### V-Glide 36 volt Vehicle

BATTERY NO.	1	2	3	4	5	6
ON-CHARGE VOLTAGE	7.86	7.33*	7.90	7.93	7.91	7.75

### PowerDrive System 48 Vehicle

BATTERY NO.	1	2	3	4	5	6
ON-CHARGE VOLTAGE	10.48	9.77*	10.53	10.57	10.55	10.33

Battery No. 2 was immediately suspected as the problem. After checking No. 2 with a hydrometer, this was clearly the case with the negative post cell completely dead. Battery No. 2 should therefore be replaced with a battery that has the same age and usage as the other batteries.

## BATTERY STORAGE

---

When storing batteries during the off-season or maintaining a replacement stock, follow these guidelines to keep batteries in good condition.

### V-Glide 36 volt Vehicles:

1. Keep the batteries clean and free of corrosion as outlined in the Battery Care section.
2. Batteries should be wired in series so they can be connected to the charger. Batteries that are in cars for winter storage can be left in the cars.
3. Fully charge the batteries prior to storage.
4. Store in a cool area. The colder the area in which the batteries are stored, the less the batteries will self discharge. Batteries stored at 0°F will discharge very little over a four-month period. Batteries stored at 80°F will have to be recharged every few weeks.

**V-Glide Storage Continued:**

5. Check the state of charge periodically. Batteries that are discharged and left in a cold environment can freeze and crack. If the specific gravity drops below 1.220, the batteries should be recharged.
6. The frequency of recharging required will depend on the temperature of the storage area, but it is recommended that the batteries be monitored for state of charge every month. Also, if the storage area is unheated in a cold climate and recharge is required, it is recommended that the area be heated to at least 60°F prior to charge. Batteries do not charge effectively in cold temperatures for the same reasons that they do not discharge as rapidly in cold temperatures.

SPECIFIC GRAVITY	FREEZING POINT
1.260	-70°F
1.230	-39°F
1.200	-16°F
1.170	-2°F
1.110	+17°F

**PowerDrive System 48 Vehicles:**

1. Keep the batteries clean and free of corrosion as outlined in the Battery Care Section.
2. Batteries should be wired in series so they can be connected to the charger. Batteries that are in cars for winter storage can be left in the cars.
3. Fully charge the batteries prior to storage.
4. Store in a cool area. The colder the area in which the batteries are stored the less the batteries will self discharge. Batteries stored at 0°F will discharge very little over a four-month period. Batteries stored at 80°F will have to be recharged every few weeks.
5. DS Electric vehicles with PowerDrive System 48 and PowerDrive Chargers are designed to be left connected, with AC power to the charger on, during off-season storage. The on-board computer will automatically analyze the batteries' state of charge every fifteen days and, if it finds the batteries low, will activate the charger as necessary. When it is time to return the vehicle to service, the batteries will already be fully charged.

# SECTION 19 - POWERDRIVE BATTERY CHARGER

## GENERAL INFORMATION

The PowerDrive Battery Charger is an integral part of Club Car's PowerDrive™ System 48, and one is included with every PowerDrive vehicle. Because it is controlled by the PowerDrive System 48 vehicle's on-board computer, it will work with only PowerDrive System 48 vehicles. The charger is totally automatic and has no external controls; when it is plugged in there is a 2 to 15 second delay, and then it comes on (**Figure 19-1**).

### NOTE

- SHORTLY AFTER CHARGING BEGINS, THE CHARGER WILL SHUT OFF AGAIN IN ORDER TO RUN A SELF-DIAGNOSTIC PROGRAM (AMMETER WILL DROP TO 0). CHARGING WILL RESUME IN A FEW MOMENTS (AMMETER RETURNS TO CURRENT STATE OF CHARGE). THIS WILL BE REPEATED AT ONE HOUR AND AT TWO HOURS INTO THE CHARGE.

The vehicle's on-board computer, having recorded the amount of energy consumed as the vehicle was used, directs the charger to replace exactly the amount of energy needed to fully replenish the batteries. The charger then shuts off automatically, preventing the possibility of either undercharging or overcharging. The computer accomplishes this by sensing when the exact amount of energy necessary has been returned to the batteries, rather than sensing voltage, rate or change of voltage, gassing point, or any other measurement parameter.

### PowerDrive System 48 charging features include:

- **CHARGE INTERLOCK**

PowerDrive Battery Charger DC plugs have three pins rather than the two blades that most standard charger plugs have. Two of these pins are the positive and negative leads as on standard chargers; the third pin is a sensing lead that is the communication link between the charger and the on-board computer. When the charger plug is plugged into the vehicle's receptacle, the on-board computer senses its presence and locks out the vehicle's drive system. This prevents the possibility of driving the vehicle while the charger is plugged in and potential damage to the vehicle and charger.

- **OFF SEASON STORAGE CHARGE**

PowerDrive System 48 vehicles and PowerDrive Chargers are designed to be left connected, with AC power to the charger on, during off-season storage. The on-board computer will automatically analyze the batteries' state of charge every fifteen days, and if it finds the batteries low, will activate the charger as necessary. When it is time to return the vehicle to service, the batteries will already be fully charged.

- **CHARGER DISCONNECT**

The computer communication pin is shorter than the positive and negative pins in the charger DC plug. In the event that the charger plug is pulled from the receptacle while the charger is in operation, the computer communication link will be disconnected first and shut the charger off before the positive and negative pins disconnect. This will help to prevent possible damage to the plug and receptacle due to arcing.

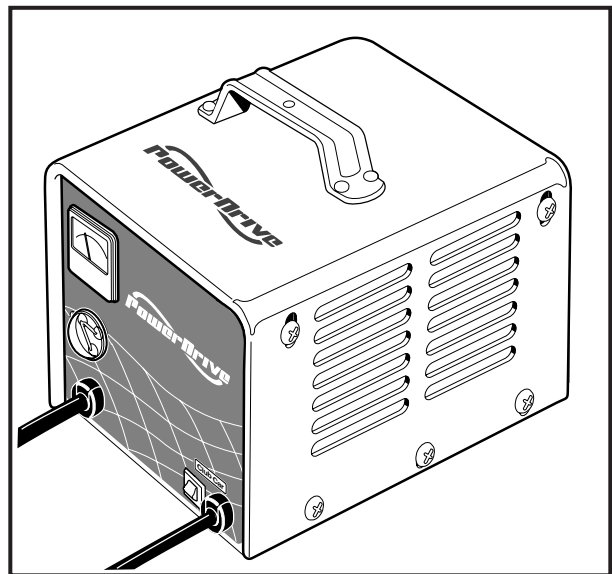

FIGURE 19-1

## Battery/Charging Trouble Light

The PowerDrive System 48 vehicle features a dash mounted warning light (above steering column) which, when the vehicle is in operation, indicates low battery voltage, or, when the vehicle is being charged, indicates a charging problem. The Battery Trouble Light is controlled by the PowerDrive System 48 on-board computer.

When the batteries receive an incomplete charge because 1) the DC power cord is disconnected, 2) AC power to the charger is interrupted, 3) automatic charger shut-off occurs after 16 hours of operation, or 4) the charger malfunctions, the trouble light will indicate as follows:

- The trouble light will not come on if the charge is 90% or more complete. The on-board computer will retain in memory the amount of charge needed to fully replenish the batteries and will complete the charge during the next charge cycle.
- When the charger is unplugged, the trouble light will come on and remain illuminated for 10 seconds if the charge is less than 90% complete but the car has enough power to complete 36 holes of golf. This will alert the fleet operator that the car may be used, but that it must be charged to completion as soon as possible.
- The trouble light will come on and remain illuminated if the charger times out at 16 hours and the batteries are not sufficiently charged. This indicates an abnormal charge cycle. The charger and batteries should be checked by your Club Car distributor/dealer.
- The trouble light will come on during a charge cycle (DC plug is still connected) if AC power to the charger is interrupted. The light will go out when AC power is restored.

## THE CHARGE CIRCUIT

The vehicle charge circuit consists of the charger receptacle, fuse link, on-board computer, and the batteries. The negative terminal of the receptacle is connected to the on-board computer. The No. 10 AWG black wire from the on-board computer (with the 5/16" terminal) connects to the negative (B-) terminal of the speed controller and from there to the negative post on battery No. 6. The positive terminal of the charger receptacle is connected to the positive post of battery No. 1. The grey wire (sense lead) from the charger receptacle is connected to the sense lead fuse, which is connected to the grey wire from the on-board computer. If the charger works with one vehicle, but does not work with another, then it can be assumed that the problem is in the charger circuit of the vehicle. Check the connections between the No. 10 grey wire from the charger receptacle, the sense lead fuse, and the No. 18 grey wire from the on-board computer. Also check connections of the fuse link assembly located on the charger receptacle (**Figure 19-2, Page 19-3**).

### **WARNING**

- ONLY TRAINED TECHNICIANS SHOULD REPAIR OR SERVICE THE CHARGER. CONSULT YOUR CLUB CAR DISTRIBUTOR/DEALER.
- DO NOT USE OR SERVICE THE CHARGER NEAR WATER.
- ALWAYS WEAR SAFETY GLASSES OR EYE PROTECTION WHILE SERVICING VEHICLE OR CHARGER.
- TURN KEY SWITCH OFF AND PLACE FORWARD AND REVERSE LEVER IN THE NEUTRAL POSITION PRIOR TO SERVICING THE CAR.
- TO AVOID UNINTENTIONAL STARTING OF THE CAR, **DISCONNECT THE BATTERIES** AND THEN **DISCHARGE THE CONTROLLER** AS FOLLOWS:
  - TURN THE KEY SWITCH TO "ON" AND PLACE THE FORWARD AND REVERSE LEVER IN THE REVERSE POSITION .
  - SLOWLY DEPRESS THE ACCELERATOR PEDAL AND KEEP IT DEPRESSED UNTIL THE REVERSE WARNING BUZZER CAN NO LONGER BE HEARD. WHEN THE BUZZER STOPS SOUNDING, THE CONTROLLER IS DISCHARGED.





## CHARGER INSTALLATION AND USE

---

The AC line to which the charger is to be connected must be capable of supplying at least 15 amperes to each charger.

### **WARNING**

- EACH CHARGER SHOULD HAVE ITS OWN 15 OR 20 AMPERE BRANCH CIRCUIT PROTECTION (CIRCUIT BREAKER OR FUSE), IN ACCORDANCE WITH THE NATIONAL ELECTRICAL CODE ANSI/NFPA 70, AND LOCAL CODES AND ORDINANCES. IMPROPER AC SUPPLY CIRCUIT PROTECTION MAY RESULT IN A FIRE.

To reduce the risk of electric shock, this battery charger must be grounded. This charger is equipped with an electric cord having an equipment-grounding conductor and a grounding type plug. It is for use on a nominal 120 volt, 60 hertz circuit. The AC plug must be connected to an appropriate receptacle that is properly installed and grounded in accordance with the National Electric Code and all local codes and ordinances.

The use of an extension cord with the charger is not recommended. If an extension cord must be used, use a three conductor No. 12 AWG cord with ground, properly wired and in good electrical condition. Keep it as short as possible (no more than twelve feet). Locate all cords so that they will not be stepped on, tripped over, or otherwise subject to damage or stress.

### **WARNING**

- IMPROPER CONNECTION OF THE EQUIPMENT-GROUNDING CONDUCTOR CAN RESULT IN RISK OF AN ELECTRICAL SHOCK.
- DO NOT USE AN ADAPTER TO PLUG THIS CHARGER INTO A TWO-PRONG OUTLET OR EXTENSION CORD. EXTENSION CORD OR OUTLET MUST ACCEPT GROUNDED THREE-PRONG PLUG.
- THE USE OF AN IMPROPER EXTENSION CORD COULD RESULT IN RISK OF FIRE OR ELECTRIC SHOCK.
- DO NOT OPERATE THIS CHARGER IF IT HAS RECEIVED A SHARP BLOW, WAS DROPPED, OR WAS OTHERWISE DAMAGED IN ANY WAY. CHECK IT TO BE SURE THAT IT IS OPERATING PROPERLY BEFORE PUTTING IT BACK IN USE.

Provide adequate ventilation for the charger. Keep all charger ventilation openings at least two inches away from walls and other objects.

### **WARNING**

- DO NOT ALLOW CLOTHING, BLANKETS, OR OTHER MATERIALS TO COVER THE CHARGER.
- CHARGERS CAN IGNITE FLAMMABLE MATERIALS AND VAPORS. DO NOT USE NEAR FUELS, GRAIN DUST, SOLVENTS, THINNER, OR OTHER FLAMMABLES.
- KEEP CHARGER DRY - DO NOT EXPOSE TO RAIN. FOR STORAGE, KEEP CHARGER INDOORS.

## NORMAL CHARGER OPERATION

### **⚠ WARNING**

- CONNECT CHARGER ONLY TO A PROPERLY GROUNDED SINGLE PHASE (3 WIRE) OUTLET.
- CHARGE BATTERIES ONLY IN A WELL VENTILATED AREA.
- TO CONNECT THE CHARGER PLUG TO THE VEHICLE RECEPTACLE, GRASP THE PLUG AND PUSH IT STRAIGHT INTO THE RECEPTACLE. DO NOT ROCK OR BEND THE PLUG SIDEWAYS.
- TO DISCONNECT THE CHARGER PLUG FROM THE VEHICLE, GRASP THE PLUG AND PULL IT STRAIGHT OUT OF THE RECEPTACLE. DO NOT PULL ON THE CORD. DO NOT TWIST, ROCK, OR BEND THE PLUG SIDEWAYS.
- DO NOT USE THIS CHARGER IF:
  - THE PLUG IS TOO LOOSE OR DOES NOT MAKE A GOOD CONNECTION.
  - THE PLUG AND/OR RECEPTACLE FEEL HOTTER THAN NORMAL.
  - THE PLUG PINS OR RECEPTACLE CONTACTS ARE BENT OR CORRODED.
  - THE PLUG, RECEPTACLE, OR CORDS ARE CUT, WORN, OR HAVE ANY EXPOSED WIRES.
  - THE PLUG, CORDS, CHARGER, OR RECEPTACLE ARE DAMAGED.
- USING THE CHARGER WITH ANY OF THE ABOVE CONDITIONS COULD RESULT IN A FIRE, PROPERTY DAMAGE, OR PERSONAL INJURY. REPAIR OR REPLACE WORN OR DAMAGED PARTS PRIOR TO USING THE CHARGER.

1. With the charger DC output cord disconnected from the batteries, connect the power supply cord to a 120 volt, 60 hertz outlet.
2. Connect the charger DC plug to the charger receptacle located on the seat support panel near the driver's knee (**Figure 19-3**). The charger will turn on automatically within 2 to 15 seconds after the DC plug is connected.

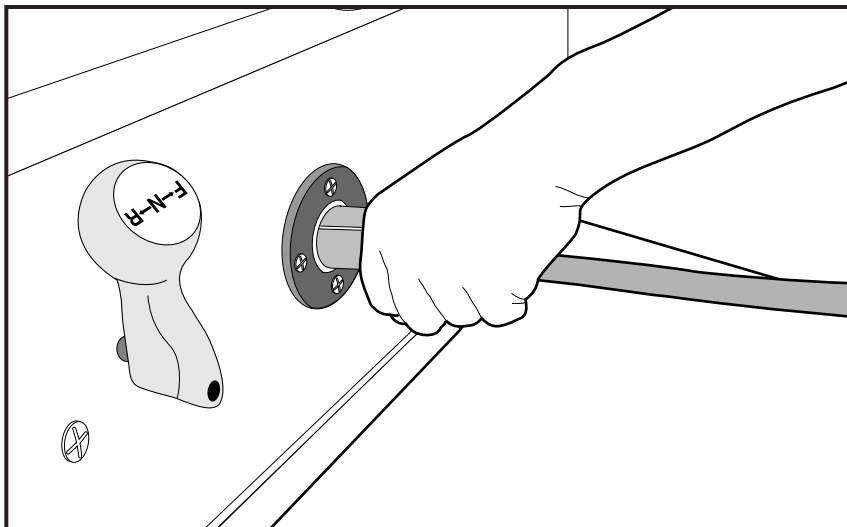

**FIGURE 19-3**

3. Monitor the ammeter for the correct charge rate. The initial charge rate will vary from 15 to 19 amps, depending upon the condition and depth of discharge of the batteries. Slight variations in the initial charge rate may also result from AC line input voltages which are higher or lower than 120 volts. Higher line voltages increase the initial charge rate and lower line voltages reduce the initial charge rate.

### Normal Charger Operation Continued:

4. Monitor the ammeter for about 30 seconds. Under normal operating conditions (when the charger is plugged into a vehicle with discharged batteries), the ammeter will drop to zero for 2 to 3 seconds at the beginning of each charge cycle in order to perform a self-diagnostic test. This test will be repeated at one hour and two hours into the charge.

#### NOTE

- IF THE BATTERIES ARE IN A FULLY CHARGED STATE AND THE VEHICLE HAS NOT BEEN DRIVEN, THE ON-BOARD COMPUTER WILL NOT PERFORM THE SELF-DIAGNOSTIC TEST.
- WHEN AIR TEMPERATURES FALL BELOW 65°F (18.3°C), BATTERIES CHARGED IN UNHEATED AREAS SHOULD BE PLACED ON CHARGE AS SOON AS POSSIBLE AFTER USE. COLD BATTERIES REQUIRE MORE TIME TO CHARGE FULLY.

### CHECKING FOR PROPER OPERATION OF CHARGER

1. With the DC plug disconnected from the receptacle, insert the AC cord into an outlet. The charger relay should **NOT** close. A DC voltmeter connected across the DC plug positive (+) and negative (-) pins should indicate zero volts. **NO** transformer hum should be heard.
2. Unplug the AC cord from its outlet and connect the DC plug to the receptacle. The charger relay should close with an audible “click” after a 2 to 15 second delay.
3. If the charger does not operate as in steps 1 or 2 above, refer to the wiring diagram (**Figure 19-4**), and check to be sure the charger is wired correctly. If the charger operates properly, then it is ready for use.

Always monitor the first charge cycle to make sure that the charger turns off properly. If the DC cord is disconnected during a charge, the Battery/Charging Trouble Light will come on if the batteries are less than 90% charged. (For more detailed information on the Battery/Charging Trouble Light, **See Battery/Charging Trouble Light, Page 19-2**).

### CHECKING BATTERY CONDITION AFTER A CHARGE CYCLE

It is common practice for golf car mechanics to check the condition of a set of batteries after they have charged in order to ensure that they have received a complete charge before the vehicle is used. With the PowerDrive System 48 this is not necessary; the vehicle’s on-board computer controls and monitors the charge cycle. If there is any problem during a charge cycle, the on-board computer will illuminate the Battery Trouble Light located above the steering column in the center dash panel. If the Battery Trouble Light is on after a charge cycle, refer to the Troubleshooting Charts on pages 19-8 through 19-12. If the specified test procedures find no problems, plug the DC cord into the vehicle and let it charge until the charger shuts off automatically. If a problem is found, correct it and then charge the vehicle. Normal voltage toward the end of a charge cycle should be approximately 59 to 63 volts.

#### TO START CHARGE CYCLE:

1. Remove the DC plug from the vehicle’s charger receptacle.

#### NOTE

- CHARGER WILL NOT OPERATE UNLESS 20 SECOND WAIT IS OBSERVED.

2. *WAIT 20 SECONDS*, and then plug the DC cord back into the vehicle.
3. Monitor the ammeter for the charge rate. If the vehicle has not been driven, the on-board computer will not perform a self-diagnostic test, the ammeter will *NOT* drop to zero, and the charge cycle will begin. If the vehicle has been driven, even if only a few feet, the on-board computer will perform the self-diagnostic test; the ammeter will drop to zero for 2 to 3 seconds before the charge cycle begins.

## ⚠ WARNING

- STUDY AND BECOME FAMILIAR WITH THE WIRING AND TERMINOLOGY OF THE CHARGER BEFORE ATTEMPTING ANY REPAIRS (FIGURES 19-4 AND 19-5).

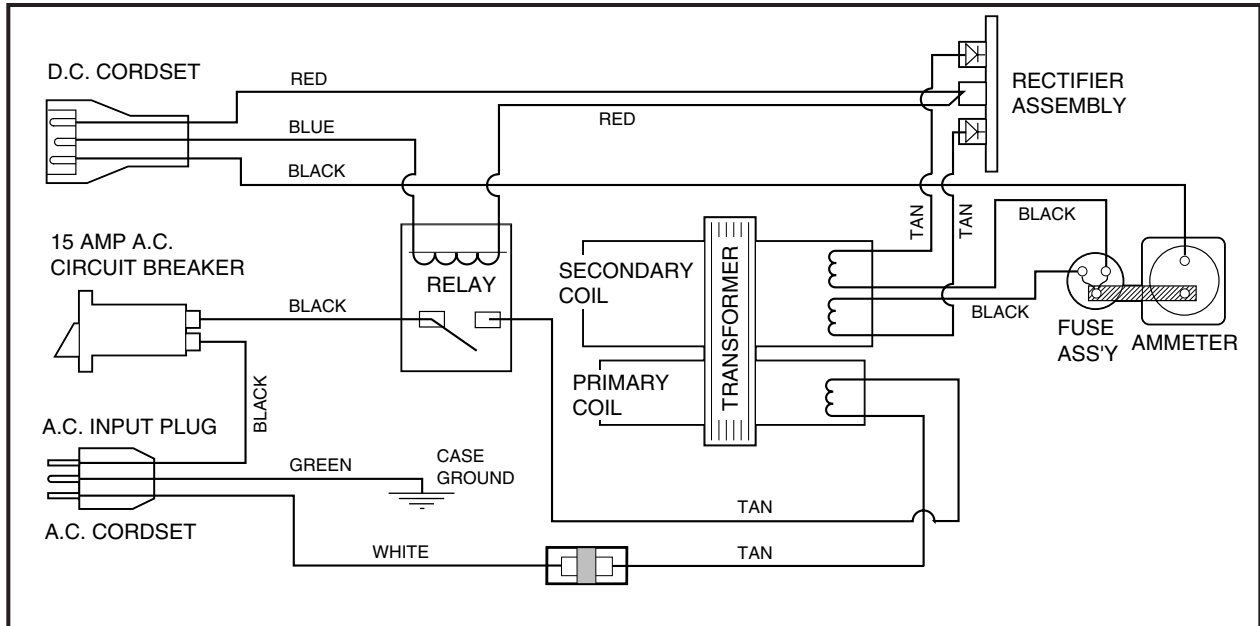

FIGURE 19-4

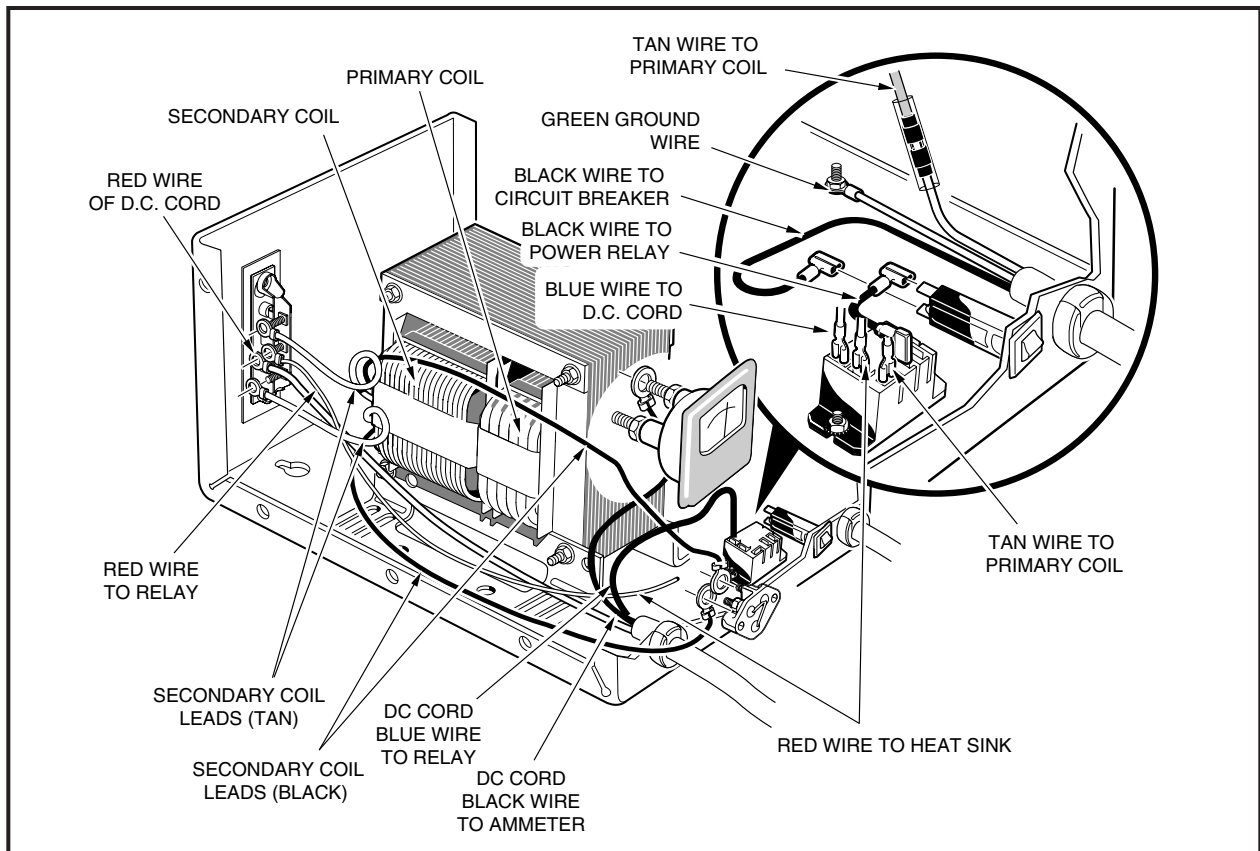
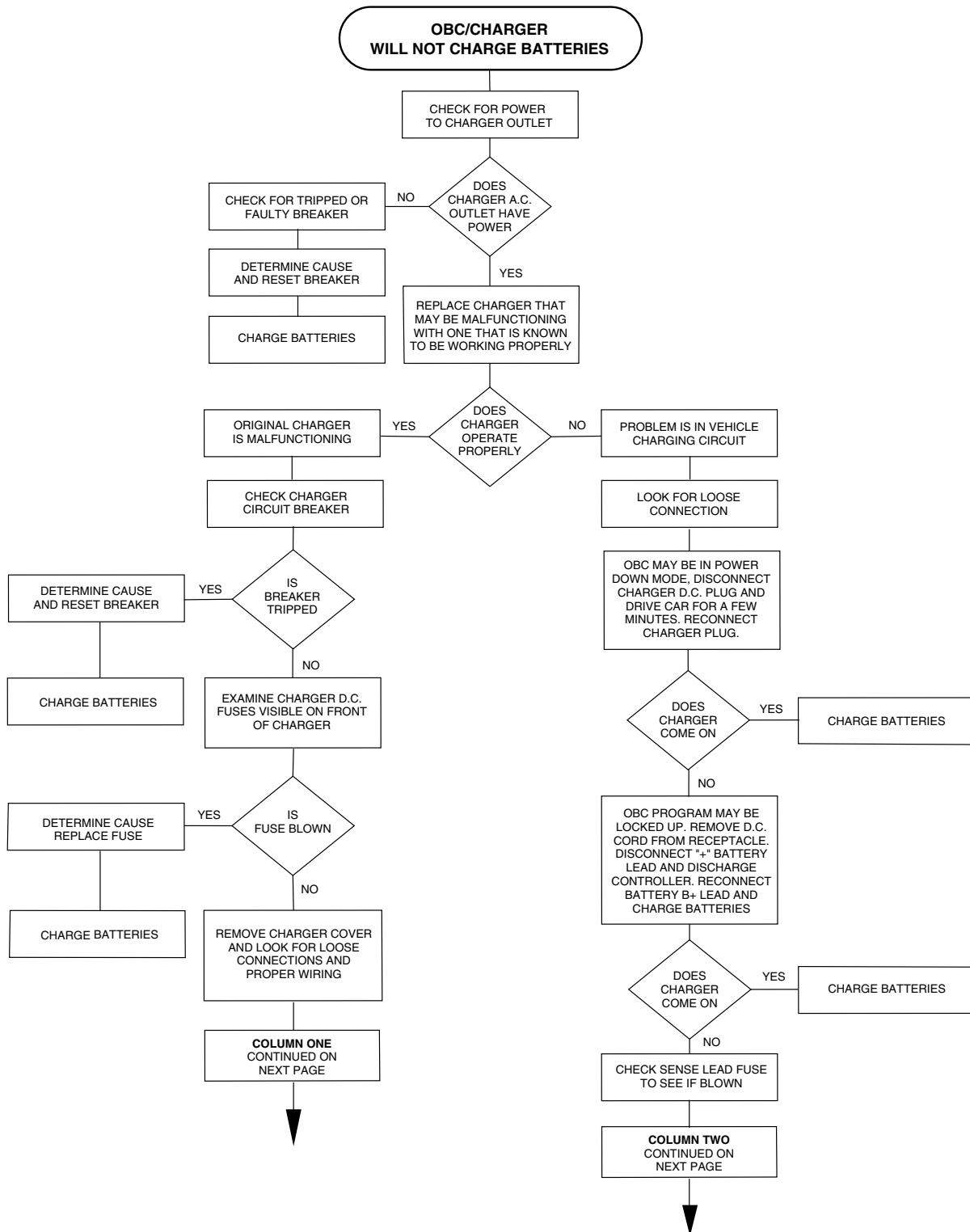

FIGURE 19-5

# TROUBLESHOOTING

Use the following charts (Pages 19-8 through 19-12) as guides for troubleshooting electric vehicles with PowerDrive System 48. The chart (below) on pages 19-8 and 19-9 refer specifically to the on-board computer and battery charger. The charts on pages 19-10 through 19-12 encompass the entire vehicle electrical system. Test procedures specified in these charts can be found on the pages immediately following the charts.



# TROUBLESHOOTING

## TROUBLESHOOTING CHART CONTINUED:

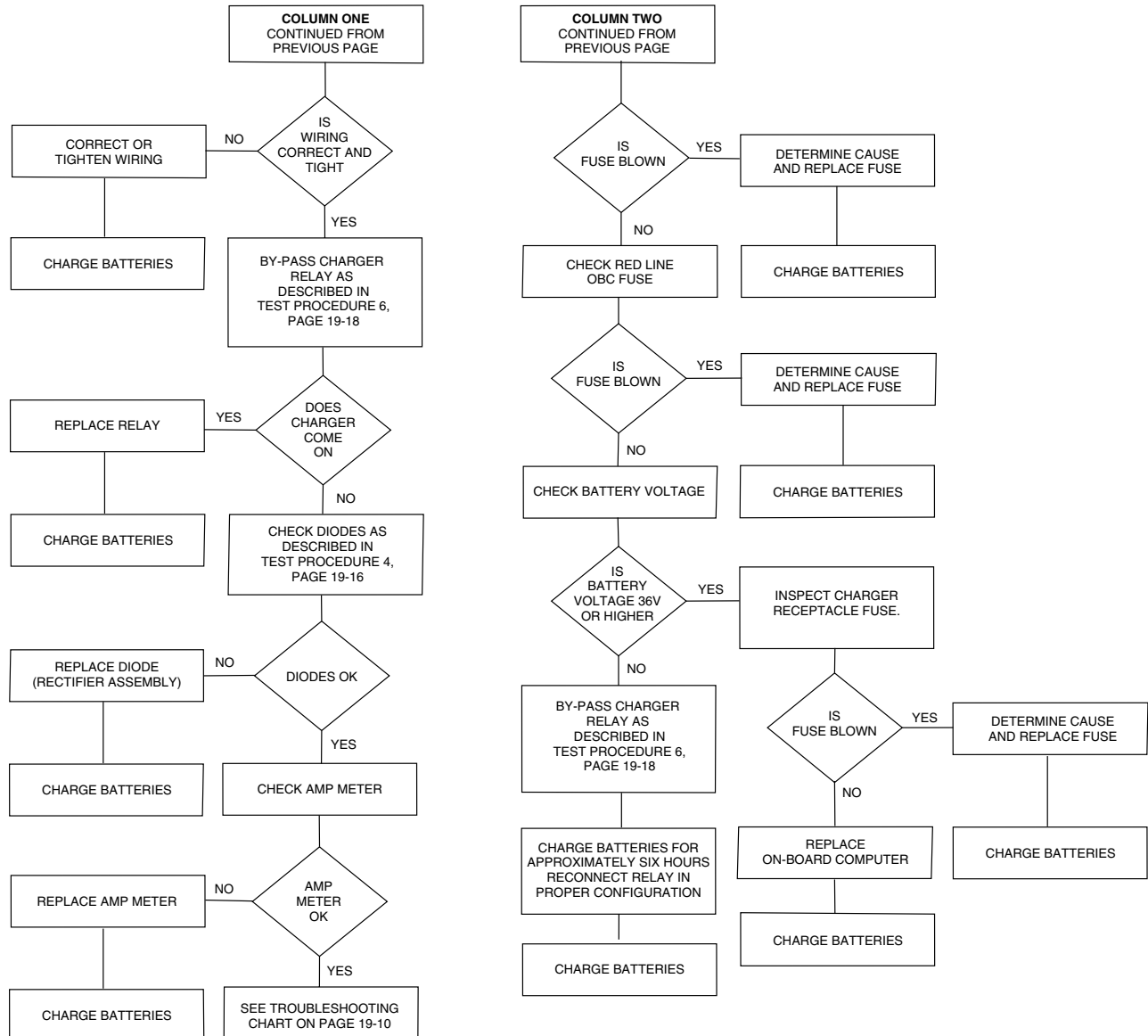

# TROUBLESHOOTING

## TROUBLESHOOTING CONTINUED:

### WARNING

- ONLY TRAINED TECHNICIANS SHOULD REPAIR OR SERVICE THE CHARGER. CONSULT YOUR CLUB CAR DISTRIBUTOR/DEALER.
- ALWAYS WEAR SAFETY GLASSES OR EYE PROTECTION WHILE SERVICING VEHICLE OR CHARGER.
- TURN KEY SWITCH OFF AND PLACE FORWARD AND REVERSE LEVER IN THE NEUTRAL POSITION PRIOR TO SERVICING THE CAR.
- TO AVOID UNINTENTIONAL STARTING OF THE CAR, **DISCONNECT THE BATTERIES** AND THEN **DISCHARGE THE CONTROLLER** AS FOLLOWS:
  - TURN THE KEY SWITCH TO “ON” AND PLACE THE FORWARD AND REVERSE LEVER IN THE REVERSE POSITION .
  - SLOWLY DEPRESS THE ACCELERATOR PEDAL AND KEEP IT DEPRESSED UNTIL THE REVERSE WARNING BUZZER CAN NO LONGER BE HEARD. WHEN THE BUZZER STOPS SOUNDING, THE CONTROLLER IS DISCHARGED.
- ALWAYS UNPLUG THE ELECTRICAL CORDS BEFORE ATTEMPTING ANY REPAIRS TO THE CHARGER. FIRST UNPLUG THE AC CORD FROM THE OUTLET AND THEN UNPLUG THE DC CORD FROM THE VEHICLE.
- WHEN CONNECTING OR DISCONNECTING THE DC PLUG, GRASP THE PLUG (NOT THE CORD) AND PUSH IT STRAIGHT INTO OR PULL IT STRAIGHT OUT OF THE RECEPTACLE.
- **DO NOT BY-PASS THE SENSE LEAD FUSE!**

### POWERDRIVE BATTERY CHARGER TROUBLESHOOTING GUIDE

SYMPTOM	POSSIBLE CAUSES	REFER TO
1. Relay does not close, no transformer hum and ammeter does not move	Batteries disconnected; reconnect	Section 17-B, Electrical
	Battery voltage too low	Test Procedure 1
	Poor connection between plug and receptacle	Test Procedure 1
	DC plug and cord	Test Procedures 1 and 5
	On-board computer malfunction	Test Procedure 2
	Grey sense lead fuse blown	Test Procedure 1
	Receptacle fuse link blown	Fuse Link, Page 19-25

## POWERDRIVE BATTERY CHARGER TROUBLESHOOTING GUIDE

SYMPTOM	POSSIBLE CAUSES	REFER TO
2. Relay closes with an audible click but no transformer hum and ammeter does not move	Check AC outlet for proper voltage	Test Procedure 3
	Failed AC plug and cord	Test Procedure 3
	Internal AC breaker	Test Procedure 3
	Transformer primary coil	Test Procedure 6
	Relay	Test Procedure 8
3. Relay closes and transformer hums but ammeter does not move	Blown charger fuse	Test Procedure 4-B
	Both diodes failed	Test Procedure 4-B
	On-board computer malfunction	Test Procedure 2
	Failed transformer	Test Procedure 6
4. Relay operates intermittently	Blown fuse on red lead from OBC	Section 17-B, Electrical
	Defective charger relay	Test Procedure 8
5. Single charger fuse link blows	Diode failed	Test Procedure 4-A
	Loose internal fuse connection	
6. Both charger fuse links blow or receptacle fuse link blows	Battery wired in reverse polarity	Test Procedure 4-B
	DC cord wired in reverse polarity	Test Procedure 4-B
	Both diodes failed	Test Procedure 4-B
7. Charger output is low	One diode failed	Test Procedure 4-A
	Transformer coil- short circuit failure	Test Procedure 6
	On-board computer malfunction	Test Procedure 2
8. Charger turns off too soon	AC power supply shut off	Test Procedure 3
	On-board computer malfunction	Test Procedure 2



## POWERDRIVE BATTERY CHARGER TROUBLESHOOTING GUIDE

SYMPTOM	POSSIBLE CAUSES	REFER TO
8. Charger turns off too soon, continued...	Batteries may be fully charged	Test Procedure 7
9. Charger goes to 16 hour time out	On-board computer malfunction	Test Procedure 2
	Extremely discharged batteries or cold temperature	Recharge batteries
	Bad battery	Section 18, Batteries
10. AC line fuse or circuit breaker blows	AC cord is shorted	Test Procedure 8
	Failed transformer	Test Procedure 6
11. Battery trouble light remains on (with DC charger cord plugged in)	AC power interrupt	Test Procedure 3
	On-board computer malfunction	Test Procedure 2
	Charger failure	See page 19-8
	16 hour time out	See page 19-2
	Battery or batteries need to be replaced	Section 18, Batteries
12. Battery trouble light remains on (with DC charger cord unplugged)	Batteries are getting close to full discharge capacity- complete golf round and place on charge immediately	Recharge batteries
	On-board computer malfunction	Test Procedure 2
	Battery or batteries need to be replaced	Section 18, Batteries

# TEST PROCEDURES

---

## GENERAL

The charger uses DC battery voltage through the on-board computer to close the charger relay that activates the charger AC circuit. When the charger is operating properly, there is a 2 to 15 second delay after the DC cord is plugged into the vehicle before the relay closes. This delay allows time for the DC plug to make a secure connection with the receptacle before the AC circuit is activated and AC power is supplied to the primary coil of the transformer. When the relay closes an audible “click” can be heard, and then as power is supplied, the transformer should hum and the ammeter should indicate the charge rate.

### CAUTION

- ONLY TRAINED TECHNICIANS SHOULD ATTEMPT TO REPAIR OR SERVICE THIS CHARGER. ANYONE DOING EVEN SIMPLE REPAIRS OR SERVICE SHOULD FOLLOW THE CORRECT PROCEDURES AND HEED THE WARNINGS STATED IN THIS MANUAL.
- ALWAYS WEAR SAFETY GLASSES OR APPROVED EYE PROTECTION WHEN SERVICING THE CAR.
- ALWAYS UNPLUG THE ELECTRICAL CORDS BEFORE ATTEMPTING ANY REPAIRS TO THE CHARGER. FIRST UNPLUG THE AC CORD FROM THE OUTLET AND THEN UNPLUG THE DC CORD FROM THE VEHICLE.

## TEST PROCEDURE 1 -

### BATTERY VOLTAGE TOO LOW OR BAD CONNECTION BETWEEN PLUG AND RECEPTACLE:

1. Check the DC plug and receptacle for damage, dirt, corrosion, or any condition that might prevent a good electrical connection.
2. Inspect the receptacle contacts to insure that they are not damaged and that they are firmly seated within the receptacle.
3. Check the wire connections to the charger receptacle:
  - 3.1 Verify that the No.10 AWG red wire from the charger receptacle is connected to the positive post of battery No. 1.
  - 3.2 Make sure that the two nuts that secure the two No. 10 AWG black wires to the receptacle fuse assembly are tight.
  - 3.3 Check the connections of the No. 10 grey wire from the receptacle to the sense lead fuse, and from the sense lead fuse to the on-board computer wire harness (**Figure 19-6, Page 19-14**).

### WARNING

- DO NOT BY-PASS SENSE LEAD FUSE!

- 3.4 Remove the grey sense lead fuse assembly and check its continuity with an ohmmeter. The resistance should be less than 2 ohms.
4. Measure the voltage of the battery pack between the positive post of battery No. 1 and the negative post of battery No. 6; normal no-load voltage will be 50 to 52 volts for fully charged batteries. The voltage of the battery pack must be over 36 volts DC in order to allow the on-board computer to close the charger relay (**Figure 19-7, Page 19-14**).

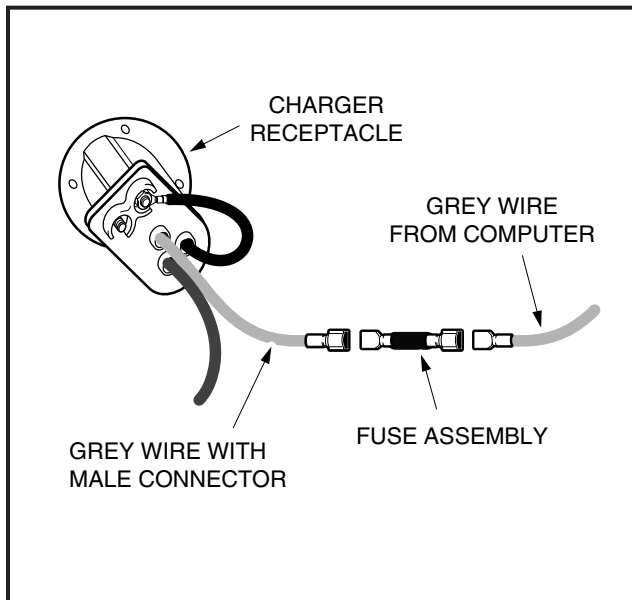

FIGURE 19-6

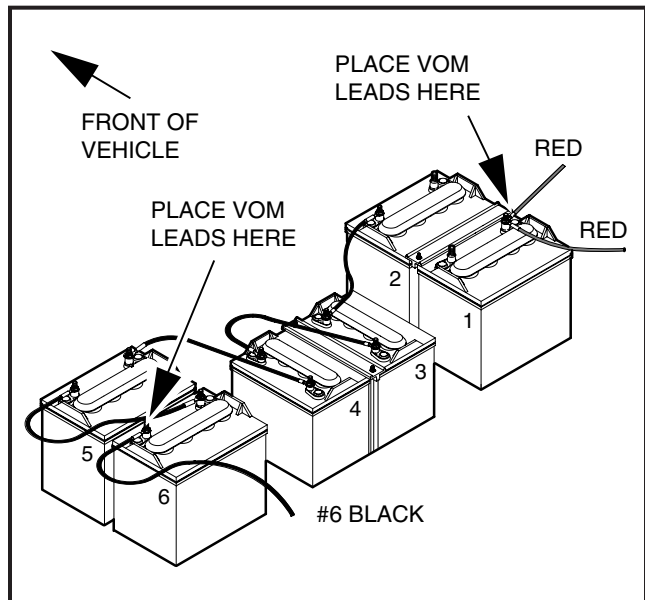

FIGURE 19-7

## TEST PROCEDURE 2 -

### ON-BOARD COMPUTER:

1. Check the circuit breaker on the front of the charger and reset if necessary.
2. Select a charger that is normally connected to another vehicle and that is known to operate properly. Leave the AC cord of the selected test charger connected to the AC outlet that it normally is connected to. This will insure that AC power is present.
3. Plug the DC cord from the selected test charger into the receptacle of the vehicle that is not charging properly.
4. If the selected test charger fails in the same manner as the charger normally used with the vehicle, then the vehicle's charging circuit is not functioning properly (**See Page 19-8, or Section 17-B, Page 17-5**).
5. Plug the original charger (thought to be malfunctioning) into another vehicle that is known to be functioning properly. If the charger performs as it should, then the charger is not in need of repair.

## TEST PROCEDURE 3 -

### **⚠ CAUTION**

- ONLY TRAINED TECHNICIANS SHOULD ATTEMPT TO REPAIR OR SERVICE THIS CHARGER. ANYONE DOING EVEN SIMPLE REPAIRS OR SERVICE SHOULD FOLLOW THE CORRECT PROCEDURES AND HEED THE WARNINGS STATED IN THIS MANUAL.
- ALWAYS WEAR SAFETY GLASSES OR APPROVED EYE PROTECTION WHEN SERVICING THE VEHICLE.
- ALWAYS UNPLUG THE ELECTRICAL CORDS BEFORE ATTEMPTING ANY REPAIRS TO THE CHARGER. FIRST UNPLUG THE AC CORD FROM THE OUTLET AND THEN UNPLUG THE DC CORD FROM THE VEHICLE.

### AC POWER AND CONTINUITY CHECK OF AC CIRCUIT:

1. Check to be sure that the AC cord is securely plugged into a live AC outlet.

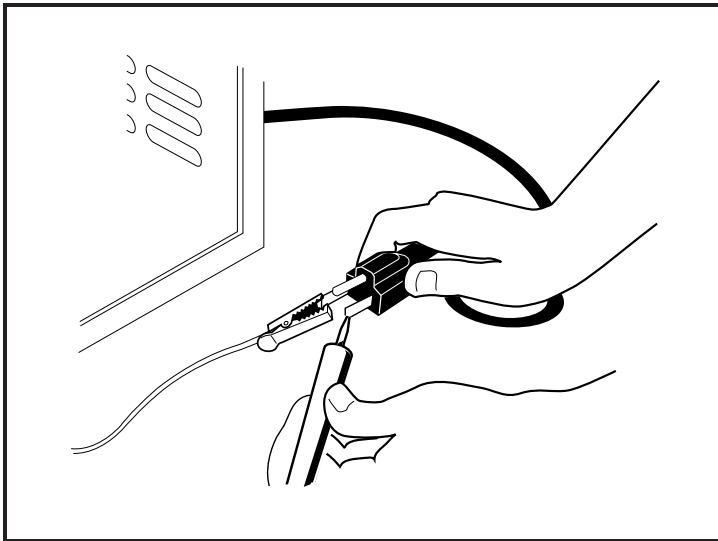

**FIGURE 19-8**

2. Check the AC circuit breaker on the front of the charger and reset it if necessary.
3. Check the AC line fuse or circuit breaker in the storage facility.
4. With VOM (Club Car Part No. 1011480) set at 500 VAC, check incoming AC voltage. Insert prongs into outlet; voltage should be 105 to 128 volts.
5. Unplug the AC power supply cord from its outlet and the DC plug from the receptacle in the golf car.
6. Check continuity of the AC circuit:
  - 6.1 Disconnect the black and tan leads from the charger relay and place a jumper between them (**Figure 19-13, Page 19-19**).
  - 6.2 With the relay by-passed, check the continuity across the AC cord prongs (**Figure 19-8**).
7. If the circuit is not complete, check the wiring of the AC cord, transformer primary coil leads, internal AC circuit breaker, and jumper wire (**Figure 19-13, Page 19-19**).
8. If the charger is wired correctly, check the continuity of the AC cord, transformer primary coil, and the jumper wire individually (**Test Procedure 8**).

## **⚠ CAUTION**

- ONLY TRAINED TECHNICIANS SHOULD ATTEMPT TO REPAIR OR SERVICE THIS CHARGER. ANYONE DOING EVEN SIMPLE REPAIRS OR SERVICE SHOULD FOLLOW THE CORRECT PROCEDURES AND HEED THE WARNINGS STATED IN THIS MANUAL.
- ALWAYS WEAR SAFETY GLASSES OR APPROVED EYE PROTECTION WHEN SERVICING THE CAR.
- ALWAYS UNPLUG THE ELECTRICAL CORDS BEFORE ATTEMPTING ANY REPAIRS TO THE CHARGER. FIRST UNPLUG THE AC CORD FROM THE OUTLET AND THEN UNPLUG THE DC CORD FROM THE VEHICLE.

## **TEST PROCEDURE 4 -**

### **DIODES:**

Use test procedure 4A for single diode failures and testing of diodes. If both diodes have failed, use test procedure 4B.

## Test Procedure 4, Continued:

### PROCEDURE 4A - SINGLE DIODE FAILURE:

A single diode failure is indicated by one fuse link blowing (closed circuit diode) or by the charger output being low (open circuit diode). If a diode has failed, the entire rectifier assembly must be replaced. To check diodes:

1. Unplug the AC cord from its outlet and the DC plug from the receptacle, then remove the charger cover.
2. Disconnect one transformer secondary coil lead from the diode terminal (**Figure 19-9**).
3. Using a low voltage continuity tester, connect the red (+) tester lead to the diode mounting plate and the other tester lead to a diode terminal and note the reading (**Figure 19-9**).
4. Reverse the tester leads and check each diode again and note the reading (**Figure 19-10**). A diode is designed to conduct current in one direction only; if a diode conducts current (shows continuity) in both directions, the complete rectifier assembly with diodes must be replaced. If a diode does not conduct current (does not show continuity) in either direction, the complete rectifier assembly must be replaced.
5. On rare occasions, a single fuse link may melt due to excessive heat. This can be caused by a loose internal fuse connection. Check all three fuse connections inside the charger to be sure that they are clean and tight. The proper torque on the fuse link connections is 20 in.lbs. (2.2 N-m).
6. Be sure that the charger is wired properly and that all connections are clean and tight.

### **⚠ WARNING**

- IF CONNECTIONS ARE NOT CLEAN AND TIGHT, EXCESSIVE HEAT WILL BE CREATED AND THE CHARGER COULD BE DAMAGED.

### PROCEDURE 4B - BOTH DIODES FAILED:

To check the diodes, use the diode test procedure 4A. If both diodes have failed closed, both charger links will be blown. If both diodes have failed open, the relay will close and the transformer will hum, but the ammeter will indicate that there is no output. If both diodes have failed open or closed, the entire rectifier assembly must be replaced. The following steps should be used to determine why both diodes failed:

1. Check the batteries and the receptacle to be sure that they are wired in the correct polarity. Also check the voltage and polarity at the receptacle.

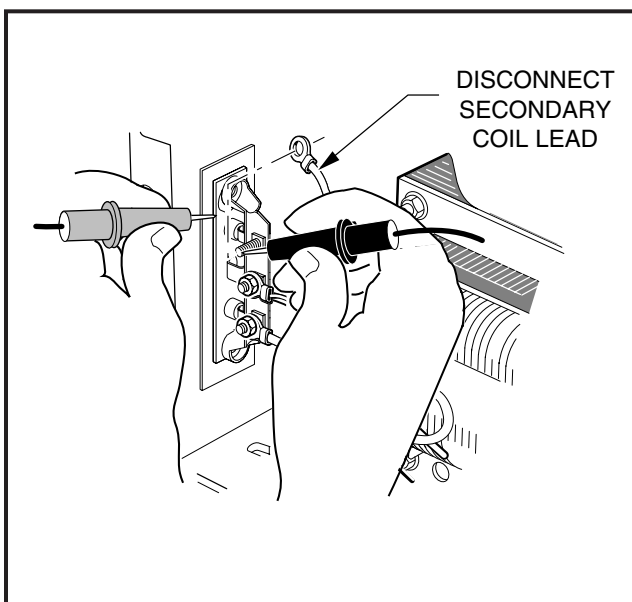

FIGURE 19-9

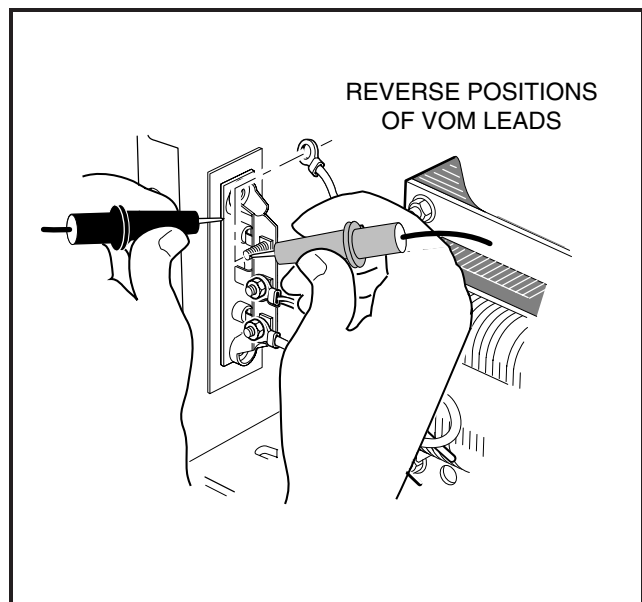

FIGURE 19-10

2. Check to be sure that the charger DC plug is wired correctly; the red wire should be connected to the center terminal of the rectifier assembly, the blue wire should be connected to the relay coil, and the black wire should be connected to the left side of the ammeter when viewed from inside the charger. If a reverse polarity connection is made between the charger and the batteries, both fuse links will blow whether or not the AC cord is plugged into an outlet.
3. Although this is rare, both diodes may fail as the result of a lightning strike at the charging location.
4. Excessive heat due to a loose connection may also cause both fuse links to melt. Be sure fuse connections are torqued to 20 in.lbs. (2.2 N-m).
5. Be sure that the charger is wired properly and that all connections are clean and tight.

## TEST PROCEDURE 5 -

### CONTINUITY TEST OF CHARGER DC CIRCUIT:

#### **⚠ CAUTION**

- ONLY TRAINED TECHNICIANS SHOULD ATTEMPT TO REPAIR OR SERVICE THIS CHARGER. ANYONE DOING EVEN SIMPLE REPAIRS OR SERVICE SHOULD FOLLOW THE CORRECT PROCEDURES AND HEED THE WARNINGS STATED IN THIS MANUAL.
- ALWAYS WEAR SAFETY GLASSES OR APPROVED EYE PROTECTION WHEN SERVICING THE CAR.
- ALWAYS UNPLUG THE ELECTRICAL CORDS BEFORE ATTEMPTING ANY REPAIRS TO THE CHARGER. FIRST UNPLUG THE AC CORD FROM THE OUTLET AND THEN UNPLUG THE DC CORD FROM THE VEHICLE.

1. Using the continuity tester (Club Car Part No. 1011273), connect the test leads to the pins marked (+) and (-) on the DC plug (**Figure 19-11**), and note the readings.
2. Reverse the test leads and check the DC plug again (**Figure 19-12**). The circuit should show continuity in only one direction.
3. If the circuit does not show continuity in either direction and the charger fuse is good, individually check the continuity of the DC plug and cord (Test Procedure 8), ammeter (Test Procedure 8), diodes (Test Procedure 4A), and all connections.

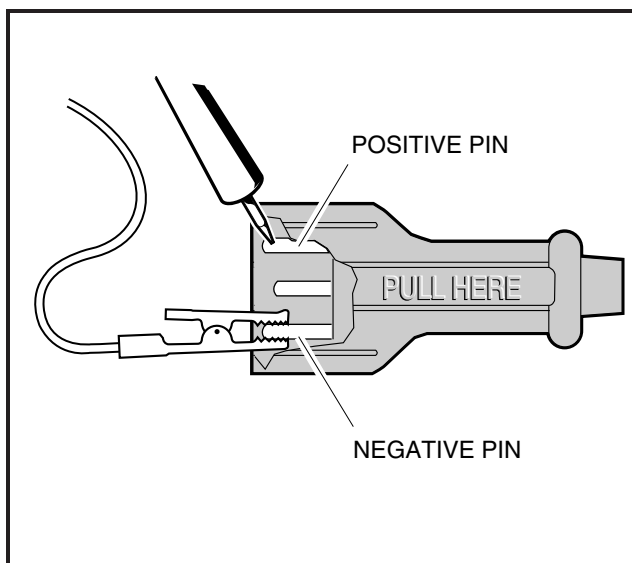

**FIGURE 19-11**

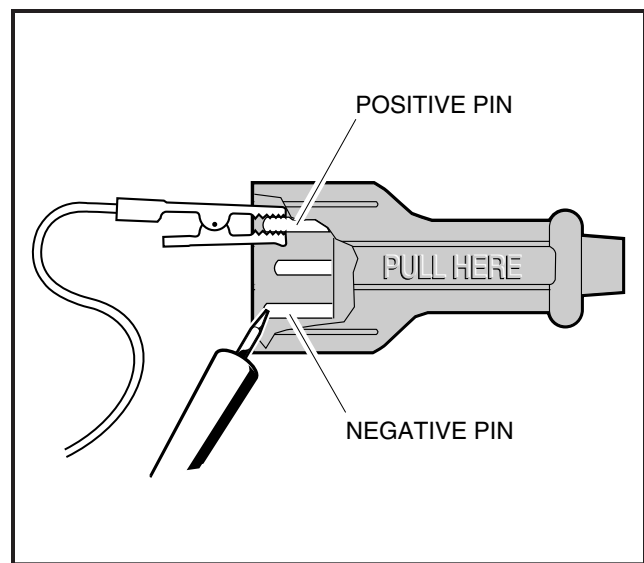

**FIGURE 19-12**

### Test Procedure 5 Continued:

4. If the circuit shows continuity in both directions, a “short” exists in the charger DC circuit, usually caused by “shorted” diodes (See Test Procedure 4). If diodes are not “shorted”, check the DC output cord for a “short” as described in Test Procedure 8.
5. Remove the blue wire from the charger relay and check the continuity between the positive and negative terminals and the middle pin on the DC plug (**Figures 19-4 and 19-5, Page 19-7**).

## TEST PROCEDURE 6 -

### TRANSFORMER:

Failure of the transformer may be caused by natural aging or shorting of adjacent coil turns. If the transformer has failed, a low or complete lack of output would be observed on the ammeter; however, the transformer may hum. A blown AC line fuse or circuit breaker in the charger and/or storage facility may have been caused by a failed transformer. To test the transformer:

### CAUTION

- ONLY TRAINED TECHNICIANS SHOULD ATTEMPT TO REPAIR OR SERVICE THIS CHARGER. ANYONE DOING EVEN SIMPLE REPAIRS OR SERVICE SHOULD FOLLOW THE CORRECT PROCEDURES AND HEED THE WARNINGS STATED IN THIS MANUAL
- ALWAYS WEAR SAFETY GLASSES OR APPROVED EYE PROTECTION WHEN SERVICING THE CAR.
- ALWAYS UNPLUG THE ELECTRICAL CORDS BEFORE ATTEMPTING ANY REPAIRS TO THE CHARGER. FIRST UNPLUG THE AC CORD FROM THE OUTLET AND THEN UNPLUG THE DC CORD FROM THE VEHICLE.

1. Disconnect the transformer secondary coil leads No. 1 and No. 5 (**Figure 19-13, Page 19-19**) from the diode terminals.
2. In order to apply AC power directly to the transformer primary coil, the relay must be by-passed.
3. Remove the black wire (3) from the circuit breaker and disconnect the tan wire (4) from the relay. Connect the tan wire to the circuit breaker (**Figure 19-13, Page 19-19**).
4. Be sure that secondary coil leads are not touching one another. With the relay by-passed, plug the AC plug into an outlet. If the AC line fuse or circuit breaker blows, the transformer is shorted internally and must be replaced (**Figure 19-13, Page 19-19**).
5. If the AC line fuse or circuit breaker does blow, check the transformer secondary voltage across leads No.1 and No. 5 using a VOM (Club Car Part No. 1011480) . If measured voltages are approximately 85 volts or lower for the secondary coil, the transformer is shorted internally and must be replaced (**Figure 19-13, Page 19-19**).

### DANGER

- DO NOT ALLOW SECONDARY COIL LEADS TO TOUCH ONE ANOTHER. THERE ARE APPROXIMATELY 120 VOLTS AC PRESENT.

6. If the transformer output measurements are 86 volts or higher, disconnect the AC plug from its outlet.
7. If the voltage readings are normal, the transformer is good. Refer to Test Procedure 5 for further tests of the DC circuit.





## Test Procedure 8, Continued:

### **⚠ CAUTION**

- ONLY TRAINED TECHNICIANS SHOULD ATTEMPT TO REPAIR OR SERVICE THIS CHARGER. ANYONE DOING EVEN SIMPLE REPAIRS OR SERVICE SHOULD FOLLOW THE CORRECT PROCEDURES AND HEED THE WARNINGS STATED IN THIS MANUAL.
- ALWAYS WEAR SAFETY GLASSES OR APPROVED EYE PROTECTION WHEN SERVICING THE CAR.
- ALWAYS UNPLUG THE ELECTRICAL CORDS BEFORE ATTEMPTING ANY REPAIRS TO THE CHARGER. FIRST UNPLUG THE AC CORD FROM THE OUTLET AND THEN UNPLUG THE DC CORD FROM THE VEHICLE.

1. Disconnect the black wire (1) of the AC cord from the charger's AC circuit breaker (3).
2. Disconnect the green wire (2) from the charger case and position it so that it does not touch any metal part of the charger.
3. Using a continuity tester (Club Car Part No. 1011273), put alligator clip on the end of the black wire and check for continuity on both flat prongs and on the ground prong of the AC plug (**Figure 19-14**). Continuity should be shown on only one flat prong. If it is shown on more than one prong, or on no prongs, the AC cord and plug must be replaced.

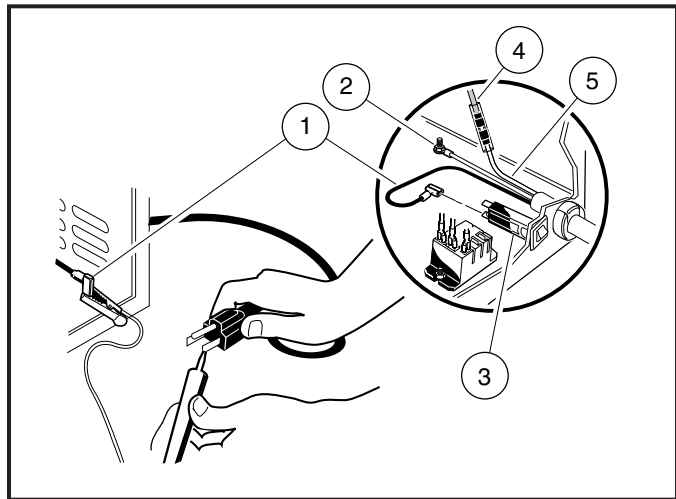

**FIGURE 19-14**

4. Put alligator clip on the end of the green wire and check for continuity on both flat prongs and on the ground prong of the AC plug. Continuity should be shown on only the ground prong. If continuity is shown on either of the flat prongs, or is not shown on the ground prong, the AC cord and plug must be replaced.
5. Disconnect the white wire (5) from the tan wire (4). Put alligator clip on the white wire and check for continuity on both flat prongs and on the ground prong of the AC plug (**Figure 19-14**). Continuity should be shown on one flat prong. If it is shown on more than one prong, or on no prongs, the AC cord and plug must be replaced.

## **DC CORD AND PLUG**

1. To check the continuity of the DC cord, disconnect the black wire of the DC cord from the ammeter.
2. Disconnect the red wire of the DC cord from the rectifier assembly.
3. Disconnect the blue wire from the relay.
4. Put the alligator clip of the continuity tester on the red wire of the DC cord.
5. Place the continuity tester probe on the positive (+) prong of the DC plug (the positive (+) prong and negative (-) prong are identified on the plug). If you do not register continuity (bulb does not light), cord and plug must be replaced.
6. Place the continuity tester probe on the negative (-) prong of the DC plug. You should register **no** continuity (bulb should not light). If you do register continuity, cord and plug must be replaced.
7. Place the continuity tester probe on the unmarked (middle) prong of the DC plug. You should register **no** continuity (bulb should not light). If you do register continuity, cord and plug must be replaced.

8. Move the continuity tester alligator clip to the black wire of the DC cord.
9. Place the continuity tester probe on the negative (-) prong of the DC plug. You should register continuity (bulb should light). If you do not register continuity, cord and plug must be replaced.
10. Place the continuity tester probe on the unmarked (middle) prong of the DC plug. You should register **no** continuity (bulb should not light). If you do register continuity, cord and plug must be replaced.
11. Move the alligator clip to the blue wire of the DC cord. Check for continuity at the middle prong; it should read continuity.

## TRANSFORMER

The PowerDrive battery charger's transformer has two coils; a primary coil and a secondary coil (**Figure 19-13, Page 19-19**).

### PRIMARY COIL

1. Disconnect terminals from transformer tan primary leads (4) and (6).
2. Touch the continuity tester leads on the primary coil leads. You should register continuity (bulb should light). If you do not register continuity, replace the transformer.

### SECONDARY COIL

1. Remove the transformer secondary coil lead (tan) from the upper terminal (1) of the rectifier assembly.

## DANGER

- **HIGH VOLTAGE!** DO NOT ALLOW SECONDARY COIL LEADS TO TOUCH EACH OTHER. THERE ARE APPROXIMATELY 120 VOLTS AC PRESENT.

2. Remove the other transformer secondary coil lead (tan) from the bottom terminal (5) of the rectifier assembly and place the alligator clip on the ammeter buss bar (7). Touch the continuity leads to each secondary coil lead (tan). You should register continuity (bulb should light). If you do not register continuity, replace transformer. Be sure that the fuse is intact and not blown.

## RELAY

## WARNING

- BEFORE PERFORMING THIS TEST, BE SURE THE AC PLUG IS **NOT** PLUGGED IN.

1. Remove the black and tan wires from the contact terminals of the relay (**Figure 19-13, Page 19-19**). Place continuity tester leads on contact terminals of the relay. Tester should show **NO** continuity (bulb should not light). If it shows continuity, the relay contacts are welded shut and the relay must be replaced.
2. With batteries connected, insert the DC plug into a receptacle. Place continuity leads on contact terminals of relay. Tester should show continuity (bulb should light). If tester does not show continuity, the relay must be replaced.

## AMMETER

To check continuity of the ammeter:

1. Disconnect the black wire from the left ammeter post (as viewed from inside the charger).
2. Place the continuity tester alligator clip on one of the ammeter posts.
3. Place the continuity tester probe on the other ammeter post. The tester should show continuity (bulb should light). If the tester does not show continuity, the ammeter must be replaced.

## PLUG AND RECEPTACLE REPLACEMENT

The charger cord, plug, and receptacle are wear items and should be inspected daily. Visually inspect them for cracks, loose connections, and frayed wiring; they *MUST* be replaced when worn or damaged. If charger plug and receptacle show signs of corrosion or are becoming difficult to insert and remove, the receptacle contacts and plug pins can be cleaned with a good electrical contact cleaner or lightly sprayed with WD-40® brand spray lubricant.

To replace receptacle, see page 17-35.

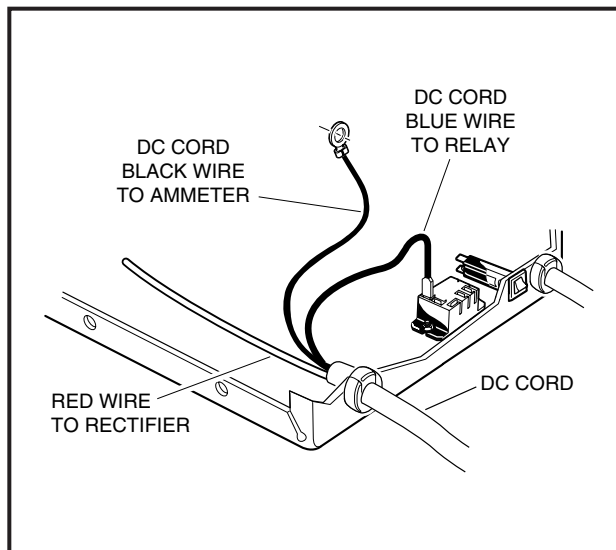

FIGURE 19-15

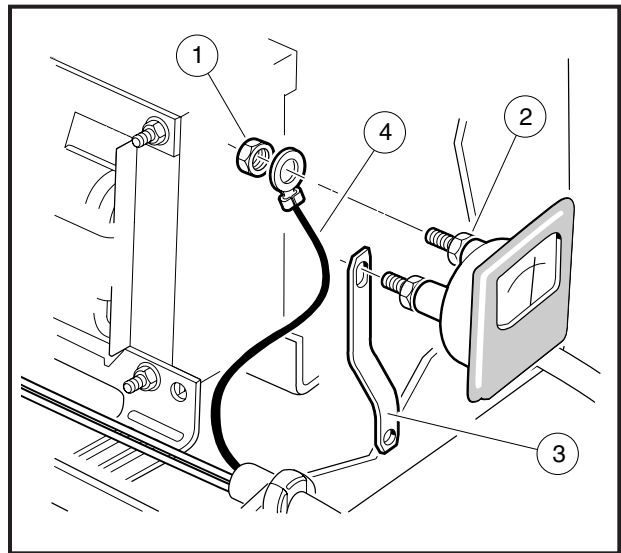

FIGURE 19-16

## CHARGER CORD REPLACEMENT

### Removal of Charger Cord and Plug:

1. Unplug the AC and DC plugs.
2. Remove the charger cover.
3. Remove the black lead of the charger DC cord from the ammeter by loosening the nut. Support the terminal as the nut is loosened to prevent rotation of the connection.
4. Remove the nut that attaches the red lead of the charger DC cord on the rectifier assembly.
5. Remove the terminal on the blue charger DC cord lead at the relay.
6. Using pliers, squeeze the strain relief bushing and remove the cord set.

### Installation of the New Charger Cord and Plug:

1. Insert the leads of the new cord through the hole in the charger base.
2. Attach the red lead of the new cord set to the terminal and torque the nut to 12-15 in.lbs. (1.4/1.7 N-m).
3. Attach the blue lead of the new cord set to the charger relay (coil) terminal (**Figure 19-15**).
4. Install nut (1) on post of ammeter slightly more than finger tight. While holding the outside nut (1), turn the inside nut (2) counterclockwise 1/4 of a turn (**Figure 19-16**).

## WARNING

- DO NOT ALLOW AMMETER POST TO ROTATE AS NUT IS TIGHTENED. IF IT ROTATES, THE AMMETER COULD BE DAMAGED.

## NOTE

- CHECK POSITION OF TERMINALS TO BE SURE THAT THEY ARE NOT TOUCHING THE AMMETER BUSS BAR (3) OR THE OTHER AMMETER POST (**FIGURE 19-16**).

5. Put the strain relief bushing on the cord and insert it into the charger base using pliers.
6. Position the charger cover on the base. Starting at the bottom holes, install the attachment screws. Torque the screws to 10-12 in.lbs. (1.1/1.4 N-m).

## CHARGER REPAIRS

### WARNING

- ONLY TRAINED TECHNICIANS SHOULD ATTEMPT TO REPAIR OR SERVICE THIS CHARGER. ANYONE DOING EVEN SIMPLE REPAIRS OR SERVICE SHOULD FOLLOW CORRECT PROCEDURES AND HEED ALL WARNINGS.

### RECTIFIER ASSEMBLY (FIGURES 19-4 AND 19-5)

#### Removal of Rectifier Assembly:

1. Remove charger cover.
2. Remove both secondary transformer leads (tan) from the rectifier assembly.
3. Remove the two red wires from the rectifier assembly.
4. Remove the nuts and bolts that secure the rectifier assembly to the case.

#### Installation of Rectifier Assembly:

1. Install the nuts and bolts which secure the rectifier assembly to the case. Torque to 12-15 in.lbs. (1.4/1.7 N-m).
2. Connect the red wire from the DC cord and the red wire from the charger relay to the center connector on the rectifier assembly. Torque nut to 12-15 in.lbs. (1.4/1.7 M-m).
3. Connect one of the secondary transformer leads (tan) to the bottom connector of the rectifier assembly. Torque nut to 12-15 in.lbs. (1.4/1.7 N-m).
4. Connect the other secondary transformer lead (tan) to the top connector of the rectifier assembly. Torque nut to 12-15 in.lbs. (1.4/1.7 N-m).
5. Replace charger cover.
6. Check charger for proper operation.

### TRANSFORMER (FIGURES 19-4 AND 19-5, PAGE 19-7)

### CAUTION

- ONLY TRAINED TECHNICIANS SHOULD ATTEMPT TO REPAIR OR SERVICE THIS CHARGER. ANYONE DOING EVEN SIMPLE REPAIRS OR SERVICE SHOULD FOLLOW THE CORRECT PROCEDURES AND HEED THE WARNINGS STATED IN THIS MANUAL.
- ALWAYS WEAR SAFETY GLASSES OR APPROVED EYE PROTECTION.
- ALWAYS UNPLUG THE ELECTRICAL CORDS BEFORE ATTEMPTING ANY REPAIRS TO THE CHARGER. FIRST UNPLUG THE AC CORD FROM THE OUTLET AND THEN UNPLUG THE DC CORD FROM THE VEHICLE.

### **Removal of the Transformer (Figures 19-4 and 19-5, Page 19-7):**

1. Remove the charger cover.
2. Disconnect the tan primary coil lead from the charger relay, then disconnect the white wire from the AC cord.
3. Disconnect the secondary transformer leads from the rectifier assembly.
4. Disconnect the secondary transformer leads from the fuse assembly.
5. Remove the four bolts and nuts that mount the transformer to the case and remove the transformer.

### **Installation of the Transformer (Figures 19-4 and 19-5, Page 19-7):**

1. Install the transformer with secondary coil to the rear of the charger case. Torque the four bolts and nuts to 25-30 in.lbs. (2.8/3.4 N-m).
2. Connect one secondary transformer lead (tan) to the top of the rectifier assembly. Torque nut to 12-15 in.lbs. (1.4/1.7 N-m).
3. Connect the other secondary transformer lead (tan) to the bottom terminal of the rectifier assembly. Torque nut to 12-15 in.lbs. (1.4/1.7 N-m).
4. Connect one secondary transformer lead (black) to one terminal of the fuse assembly. Torque nut to 20-24 in.lbs. (2.3/2.7 N-m).
5. Connect the other secondary transformer lead (black) to the remaining terminal of the fuse assembly. Torque nut to 20-24 in.lbs. (2.3/2.7 N-m).
6. Connect the tan primary lead to the charger relay.
7. Connect the other primary lead to the white wire from the AC cord.
8. Replace charger cover.
9. Check charger for proper operation.

### **AMMETER (FIGURE 19-17):**

#### **Removal of Ammeter**

1. Remove charger cover.
2. Disconnect black wire from the DC cord (5), and the buss bar (3) from the ammeter (**Figure 19-17**).
3. Remove the two nuts (2) that secure the ammeter to the charger face.
4. Remove the ammeter from the face of the charger.

#### **Installation of Ammeter:**

1. Place the ammeter in position in the charger face.
2. Install the washers and nuts and tighten until ammeter is firmly secured.
3. Connect the black wire of the DC cord to the left (when viewed from inside the charger) post of the ammeter.
4. Connect the buss bar from the fuse link to the right post of the ammeter, placing washers on both sides of the buss bar.
5. Thread nuts onto both posts of the ammeter until just past finger tight. While holding the outside nut, turn the inside nut counterclockwise 1/4 of a turn.
6. Replace the charger cover.
7. Plug the charger into vehicle and check to be sure that ammeter is operating properly.

## FUSE LINK

### Removal of Fuse Link:

1. Remove the charger cover.
2. Remove both secondary transformer leads and the buss bar from the back of the fuse link assembly.
3. Remove screws from the front of the charger and remove the fuse link assembly.

### Installation of Fuse Link:

1. Place plastic cover over fuse assembly and install mounting screws from front of charger face. Center branch of fuse assembly should be in the upper left corner when viewed from the front of the charger.
2. Install the buss bar over the center branch of the fuse assembly and ammeter stud. Torque to 24-30 in.lbs. (2.7/3.4 N-m).
3. Install a secondary transformer lead (black) to one of the two remaining terminals on the back of the fuse assembly. Install the remaining secondary transformer lead (black) to the remaining terminal. Torque to 24-30 in.lbs. (2.7/3.4 N-m).
4. Replace charger cover.

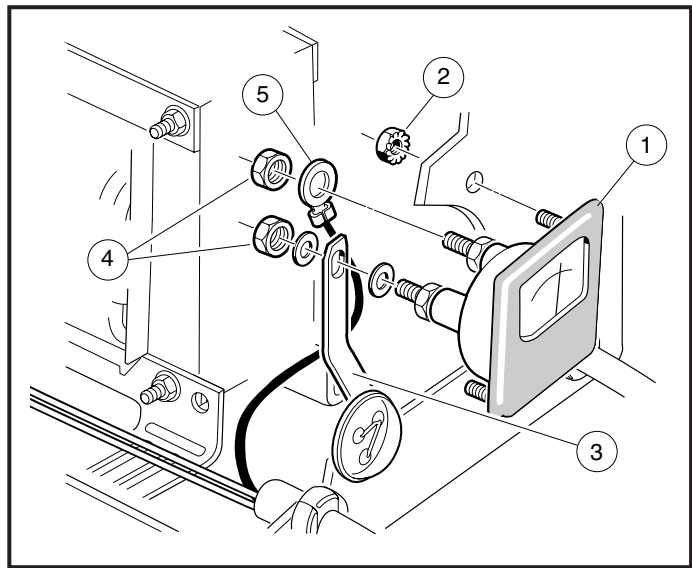

FIGURE 19-17

## CHARGER RELAY (FIGURE 19-18, PAGE 19-26)

### Removal of the Charger Relay:

1. Unplug the AC and DC cords.
2. Remove the charger cover.
3. Disconnect the red, blue, black, and primary coil wires from the relay.
4. Remove the two 5/16 inch nuts and lock washers attaching the relay to the charger base.
5. Remove the relay.

### Installation of the Charger Relay:

1. Install in reverse order of removal.

## CHARGER AC CIRCUIT BREAKER (FIGURE 19-18, PAGE 19-26)

### Removal of the AC Circuit Breaker:

1. Unplug the AC and DC cords.
2. Remove the charger cover.
3. Disconnect the two black wires attached to circuit breaker.
4. With a pair of pliers, squeeze in the retaining tabs on the sides of the circuit breaker and remove the circuit breaker through its mounting hole in the face of the charger.

### Installation of the AC Circuit Breaker:

1. Install in reverse order of removal.

## CHARGER AC CORD (FIGURE 19-18)

### Removal of the AC Cord:

1. Unplug the AC and DC cords.
2. Remove the charger cover.
3. Disconnect the AC cord black wire at the circuit breaker.
4. Disconnect the AC cord white wire at the primary coil.
5. Disconnect the AC cord green wire at the charger base.
6. Use a pair of pliers to grip the strain relief bushing and remove it and the AC cord from the charger.

### Installation of the AC Cord:

1. Insert the black, white, and green leads of the new AC cord into the charger through the hole in the charger face.
2. Connect the black wire to the circuit breaker, the white wire to the primary coil, and the green wire to the charger base.

### NOTE

- MAKE SURE THAT THE GREEN (GROUND) WIRE IS TIGHTLY SECURED TO THE CHARGER BASE.

3. Position the strain relief bushing on the AC cord.
4. Using pliers, install the strain relief bushing into the mounting hole in the charger face.
5. Install the charger cover.

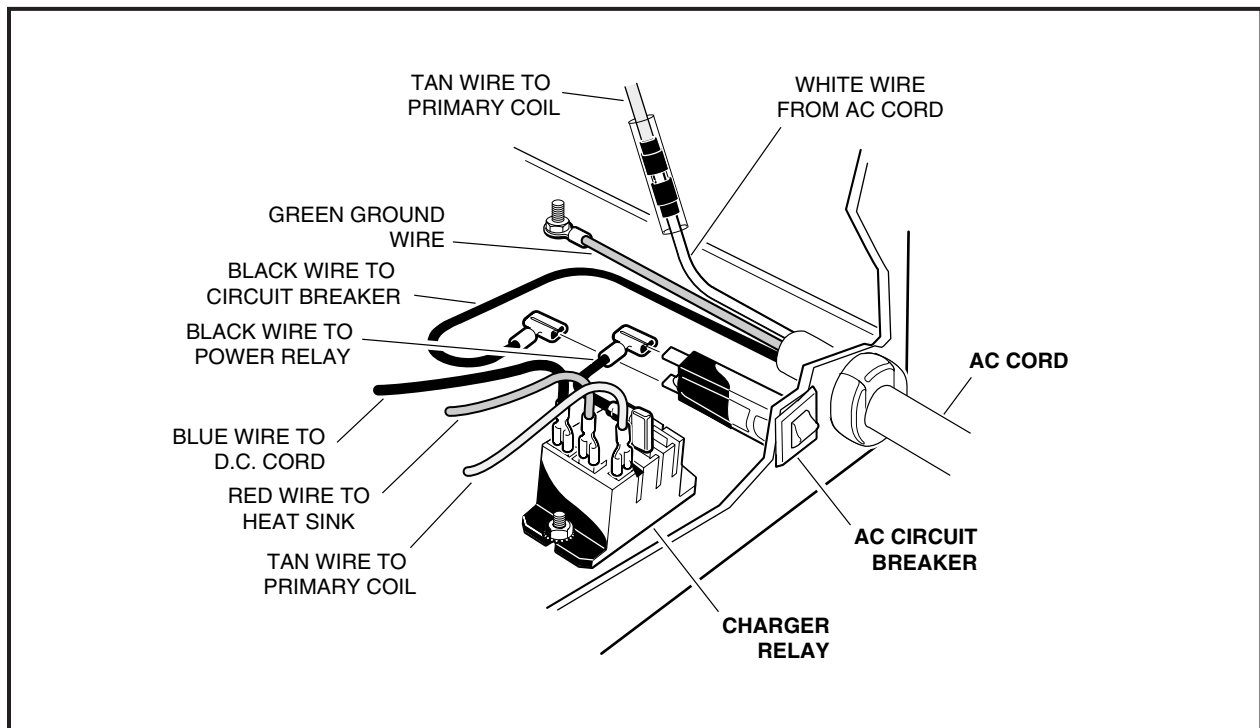
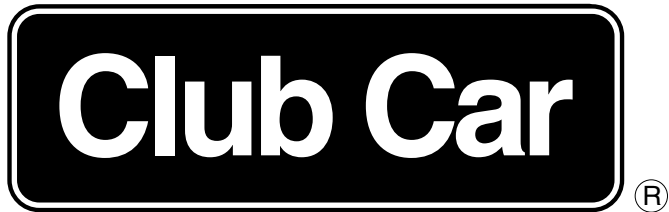

FIGURE 19-18



## **PEDAL GROUP ADJUSTMENT INSTRUCTIONS**

---

ALL CLUB CAR VEHICLES

New Pedal Group Incorporation  
Effective 2-6-95

Bulletin No. 95-5 (Revised)



# 1

## GENERAL PRECAUTIONS

1. Before you begin adjustment of the pedal group, please take time to read these instructions, review safety procedures, and familiarize yourself with the parts described in these instructions.
2. **OBSERVE THE FOLLOWING WARNINGS!** Failure to do so may result in severe personal injury and (or) damage to the vehicle or property:



**ONLY TRAINED PEOPLE SHOULD SERVICE OR REPAIR THE VEHICLE.**



**ANYONE SERVICING, REPAIRING, OR INSTALLING OPTIONAL EQUIPMENT ON A CLUB CAR VEHICLE, NO MATTER HOW SIMPLE THE OPERATION, SHOULD FOLLOW PROPER PROCEDURES AND HEED WARNINGS IN THIS AND ALL OTHER APPLICABLE PUBLICATIONS.**



**ALWAYS WEAR APPROVED EYE PROTECTION WHEN SERVICING THE VEHICLE.**



**BEFORE BEGINNING WORK ON THE VEHICLE, PARK IT ON A FIRM AND LEVEL SURFACE, TURN THE KEY SWITCH TO OFF, PLACE THE FORWARD/REVERSE LEVER IN THE NEUTRAL POSITION, AND ENGAGE THE PARKING BRAKE.**



**ALWAYS DISCONNECT BATTERY CABLES AS INSTRUCTED IN THE APPROPRIATE CLUB CAR MAINTENANCE AND SERVICE MANUAL.**

# 2

## TOOLS YOU WILL NEED

QTY.	DESCRIPTION
1	SCREW DRIVER, MED. PHILLIPS
1	WRENCH, 5/16" COMBINATION
1	WRENCH, 1/2" OPEN END
1	WRENCH, 3/8 DRIVE TORQUE, CLICKER TYPE, IN.LBS.
1	WRENCH, 3/8 DRIVE TORQUE, CLICKER TYPE, FT.LBS.
1	SOCKET, 1/2", 3/8 DRIVE
1	SOCKET, 7/16", 3/8 DRIVE
1	GAUGE, FEELER
1	MULTIMETER
1	JACK, 1000 LB. CAPACITY
2	JACKSTANDS
1	TOOL, ACCELERATOR PEDAL ADJUSTMENT

# 3

## IDENTIFYING THE NEW PEDAL GROUP (FIGURE 1).

The new pedal group was incorporated 02/06/95 (Serial No. 445799 and greater) on electric vehicles, and on 02/07/95 (Serial No. 445519 and greater) on gasoline powered vehicles. The new pedal group differs from the old style in the following ways:

1. On all vehicles, the accelerator pedal extension spring has been replaced by a compression spring.
2. On all vehicles, the pivot rod supports are now injection molded with replaceable composite bearings.
3. On electronic controller (PowerDrive System 48) vehicles, the multi-step potentiometer has been replaced by a continuously variable potentiometer.
4. New adjustment procedures are as follows:

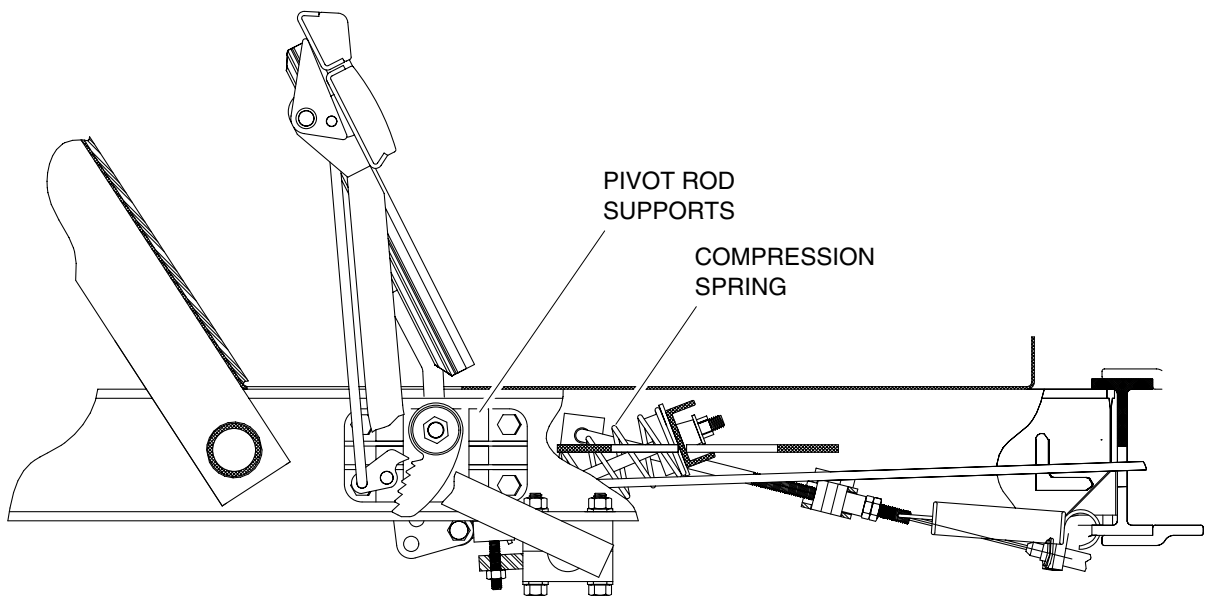

**FIGURE 1**

# 4

## RAISE THE VEHICLE AND SECURE IT ON JACK STANDS.

### WARNING

- LIFT ONLY ONE END OF THE VEHICLE AT A TIME. CHOCK THE WHEELS AND LOCK HILL BRAKE BEFORE LIFTING. USE A SUITABLE LIFTING DEVICE (CHAIN HOIST OR HYDRAULIC FLOOR JACK) WITH 1000 LBS. (454 KILOGRAMS) MINIMUM LIFTING CAPACITY. **DO NOT** USE LIFTING DEVICE TO HOLD VEHICLE IN ELEVATED POSITION. ALWAYS USE APPROVED JACK STAND OF PROPER WEIGHT CAPACITY TO SUPPORT VEHICLE.

- 4.1. Chock rear wheels, then raise the front end of the vehicle and rest it on jackstands positioned at each end of the round frame cross-member located beneath the junction of the flat and inclined portions of the floorboard (Figure 2).
- 4.2. Release the hill brake.

# 5

## ADJUST BRAKE PEDAL HEIGHT (FIGURE 2).

- 5.1. Using a 7/16" socket, loosen brake stop jam nut (Item 1) and adjust brake stop bumper (Item 2) up or down. Adjusting the bumper upwards decreases distance between pedal and floorboard. Adjusting bumper downwards increases distance between pedal and floorboard. Proper brake pedal height is 5-3/4" plus or minus 1/4". Tighten jam nut to 7 - 9 ft.lbs.

# 6

## ADJUST HILL BRAKE RATCHET (ITEM 3) / PAWL (ITEM 4) GAP AND PAWL ENGAGEMENT. (FIGURE 2)

- 6.1. Using a 1/2" wrench, adjust retaining nut (Item 5) on spring support rod until there is a .030 to .090 inch gap between the pawl and the tips of the ratchet teeth. Use a feeler gauge to verify gap ( See Figure 2, Detail A).

### NOTE

- On all DS Electric vehicles with electronic controllers, the actuator lever must also be adjusted (step 8) if the ratchet/pawl gap is adjusted.
- On DS V-Glide Electric and Gasoline powered vehicles, the accelerator rod adjustment must also be checked if the ratchet/pawl gap is adjusted. See DS Maintenance and Service Manual.
- On DS V-Glide Electric and Gasoline powered vehicles, the accelerator push rod must be disconnected from the accelerator pedal before proceeding to step 6.2.

- 6.2. Measure distance from the top of the accelerator pedal to the floorboard, and then lock the park brake.
- 6.3. With the park brake locked, make sure that at least 75% of ratchet tooth length engages the pawl ( See Figure 2, Detail B).
- 6.4. Then, with the park brake still locked, measure the distance from the top of the accelerator pedal to the floorboard again. If the measurement has changed, ratchet tooth engagement is too deep.
- 6.5. If ratchet/pawl engagement must be adjusted, separate ball joint at the top of the hill brake rod and thread the ball joint sleeve clockwise to increase engagement or counter-clockwise to decrease engagement. Reconnect ball joint.
- 6.6. If it was disconnected, reconnect accelerator push rod to accelerator pedal.

## ADJUST ACCELERATOR PEDAL HEIGHT - ALL VEHICLES.

7.1. Using a 1/2" socket and 1/2" wrench, loosen nut and bolt (Items 1 and 2, Figure 3) securing accelerator pedal to pivot plate. Using the accelerator pedal adjustment tool (Club Car Part no. 1018710) clamped to the accelerator pedal, with "accelerator pedal height" toward floorboard, position pedal at 5-5/8" plus or minus 1/8" as shown in Figure 3. Tighten nut to 12-15 ft.lbs.

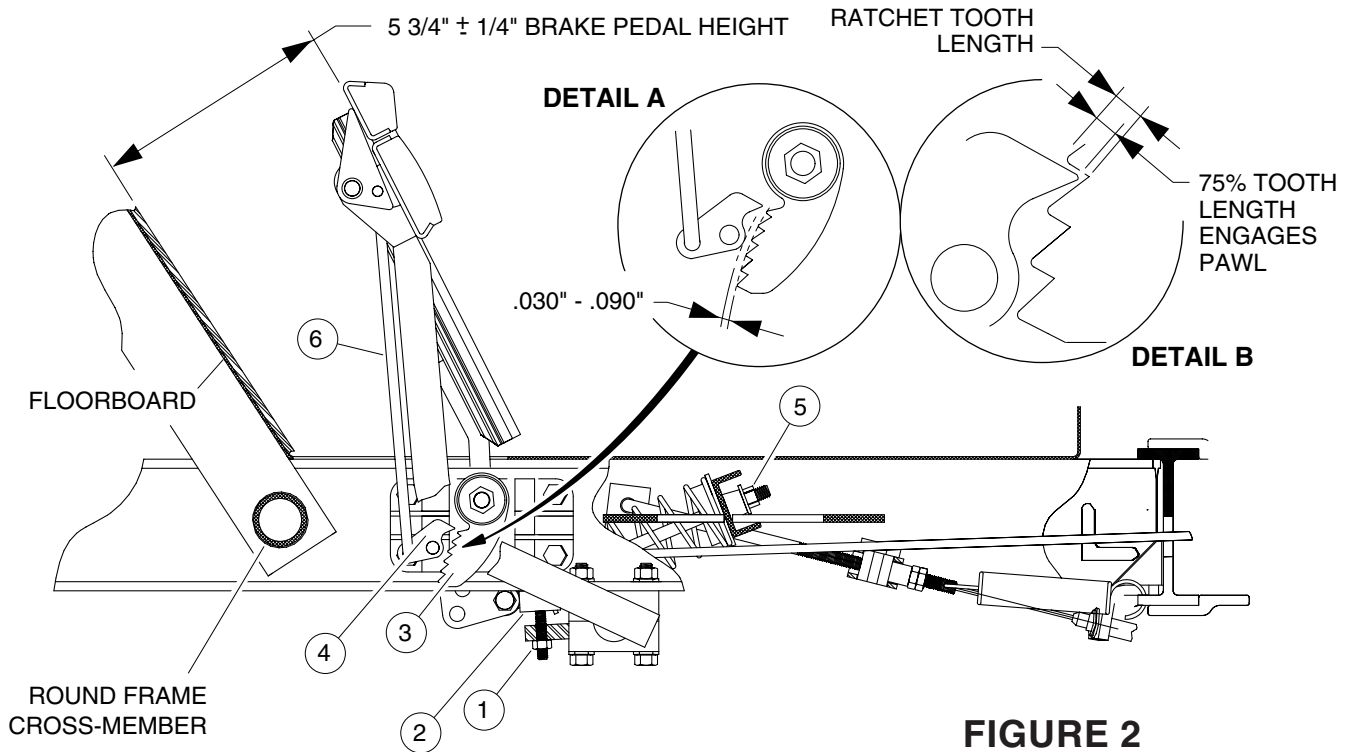

**FIGURE 2**

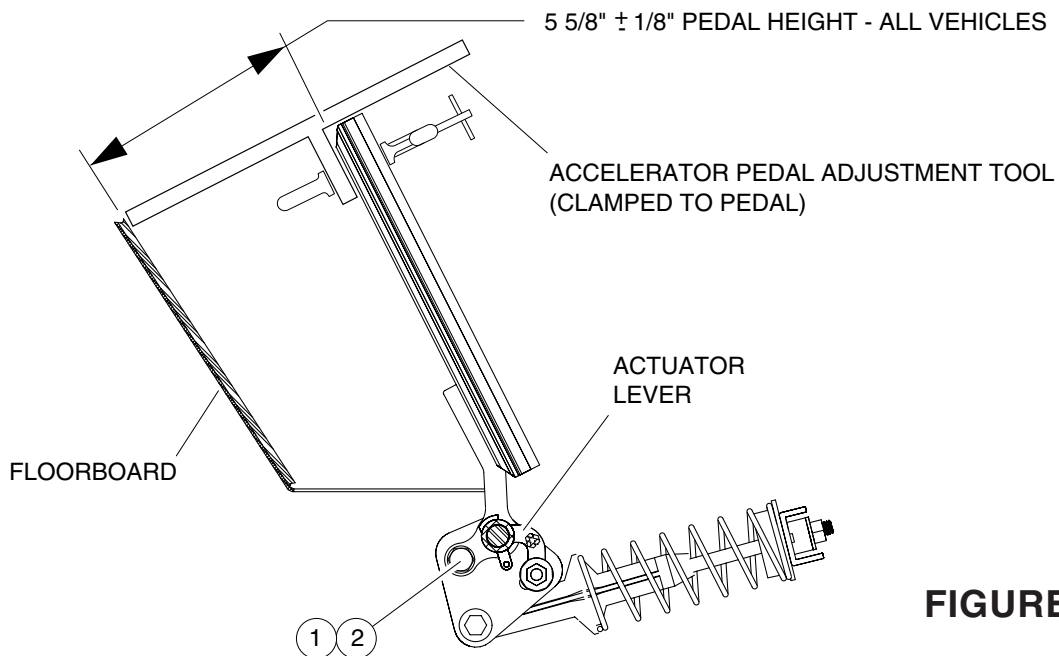

**FIGURE 3**

## ADJUST ACTUATOR LEVER - ELECTRONIC CONTROLLER VEHICLES ONLY. (FIGURE 4)

- 8.1. Reposition and clamp the Accelerator Pedal Adjustment tool on the accelerator pedal with the side marked "micro break point" towards the floorboard, then depress the accelerator until a pedal height of 4-5/8" plus or minus 3/32" is reached. Place a weight on pedal to hold it in depressed position.
- 8.2. Use a phillips screw driver to remove screws (Item 1) and detach potentiometer housing cover.
- 8.3. Using a 7/16 wrench, slightly loosen bolt (Item 5) attaching actuator lever to adjustment bracket.
- 8.4. Disconnect wires from the accelerator microswitch (Item 2). Set a multimeter to "ohms" and place the probe across the connector tabs. Rotate the actuator lever (Item 3) on the pivot rod weldment (Item 4) clockwise until microswitch makes a closed circuit (multimeter reads approximately zero).
- 8.5. Now rotate the actuator lever counter-clockwise to exactly the point where the microswitch breaks the circuit (multimeter reads open circuit).
- 8.6. Without moving the actuator lever, tighten the bolt (Item 5) attaching actuator lever to adjustment bracket located on the accelerator pivot rod weldment (Item 4). Torque to 70-80 in.lbs.

### NOTE

- The potentiometer is preset at the factory and should not require adjustment. If a problem is suspected, the potentiometer settings may be set as follows:
  1. Disconnect the three-wire connector in the battery compartment under the seat. It is located on the front seat support panel below the charger receptacle.
  2. Connect multimeter, set to "ohms" position, between purple and yellow wire terminals.
  3. Using a 5/16 wrench, loosen the nut (Item 6); potentiometer resistance should be set to between 150 and 300 ohms.
  4. Depress accelerator to floor; potentiometer resistance should measure between 4600 and 6400 ohms.

- 8.7. Replace potentiometer housing cover.

## 9

CAREFULLY SUPPORT VEHICLE WITH LIFTING DEVICE, REMOVE JACKSTANDS, AND LOWER VEHICLE TO GROUND. CONNECT THE BATTERIES.

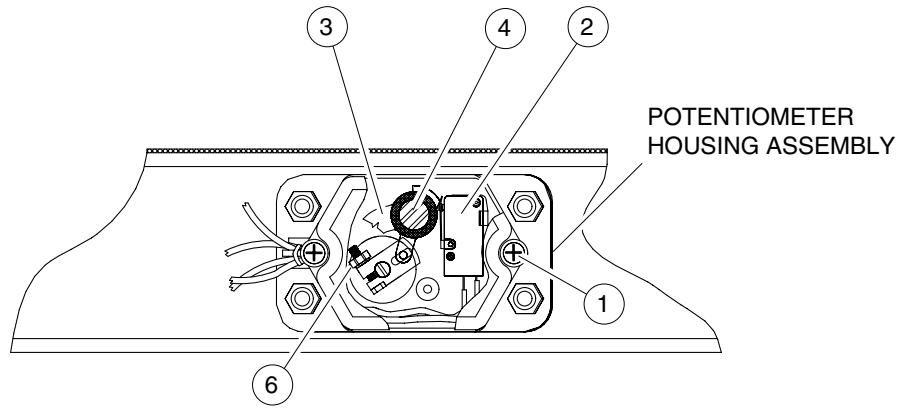

SIDE VIEW OF POTENTIOMETER HOUSING ASSEMBLY  
WITH COVER CUT AWAY

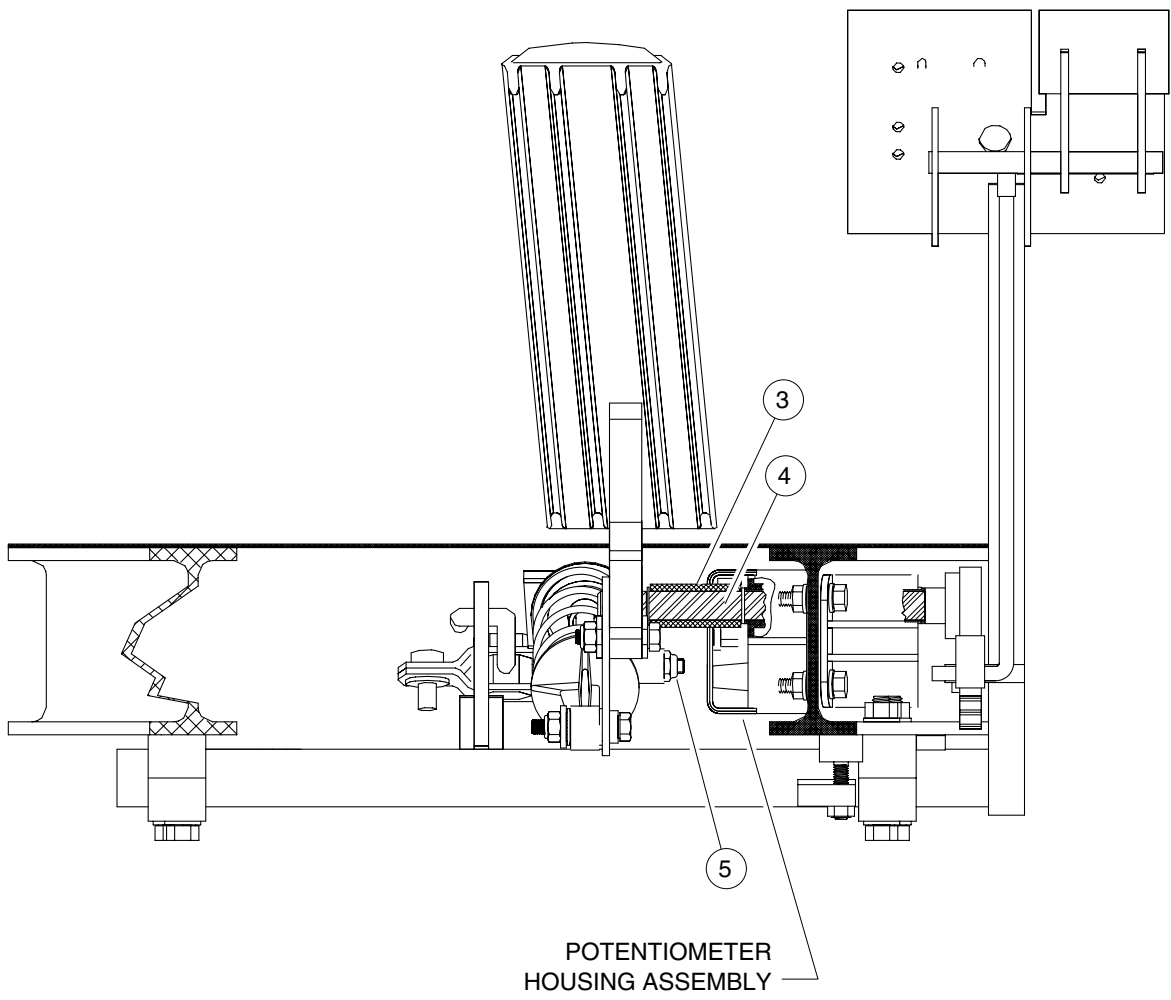

FIGURE 4











