

Curtis 1268-5403

This sheet is provided to aid in the installation of your remanufactured CURTIS controller. Upon installation, you may encounter problems that may, or may not, be due to a faulty controller. The following steps must be taken to help diagnose a possible cart fault or faulty controller. An analog or digital volt ohm meter (VOM) will be needed to perform these checks.



WARRANTY WILL BE VOID **If These Steps are Not Performed Before Installing The Control**

➔ STEPS TO PERFORM **BEFORE** CONTROL INSTALLATION ←➔

CHECK MOTOR WINDINGS:

- Set your VOM to RESISTANCE (Ω).
- To test the resistance of VOM leads, please touch the meter leads together. Subtract this measurement from each test below to get your true measurement.
- With motor disconnected, measure A1 to A2. This should measure approximately BETWEEN $.2\Omega$ and 2Ω .
- With motor disconnected, measure F1 to F2. This should measure approximately BETWEEN $.8\Omega$ and 3Ω .
- With motor disconnected, measure A1 to F1. This should measure OPEN.
- With motor disconnected, measure F1 to motor case. This should measure greater than $5M\Omega$.

CHECK MAIN SOLENOID:

- Disconnect all wires from the main solenoid.
- Set your VOM to RESISTANCE (Ω).
- Measure the solenoid coil. This should measure 100Ω - 250Ω (depending on solenoid type).
- Connect VOM leads to the main solenoid lugs.
- Attach jumpers from main battery positive and negative to the coil (small terminals).
- Meter should jump from infinity to LESS THAN $.3\Omega$.
- Remove jumpers and reconnect solenoid wiring from the harness. (If suppression diode is present, the non-banded side must go to the wire from J1 pin 17 from the controller. Be sure to check diode functionality with VOM prior to install. If pre-charge resistor is installed, please remove. This control is equipped with an internal resistor, and installing one on the solenoid could cause damage to the control.)

CHECK THE CART WIRE HARNESS:

- Check the connectors on the wire harness for corrosion, loose, broken, burnt or missing pins.
- Repair or replace pins as necessary.

**IF ANY OF THE ABOVE ITEMS ARE NOT WITHIN THE SPECIFIED RANGES THE CONTROLLER WILL FAIL.
THESE ITEMS MUST BE CORRECTED BEFORE THE CONTROLLER IS INSTALLED OR WARRANTY WILL BE VOID.**

It is recommended to replace your solenoid at the time of controller replacement. FSIP now stocks popular replacement White Rodaers solenoids for your convenience.

36V/48V Battery Pack

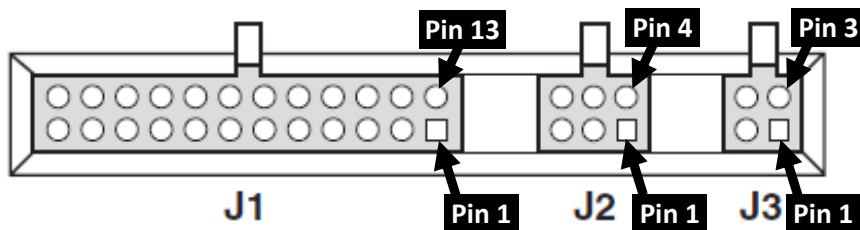
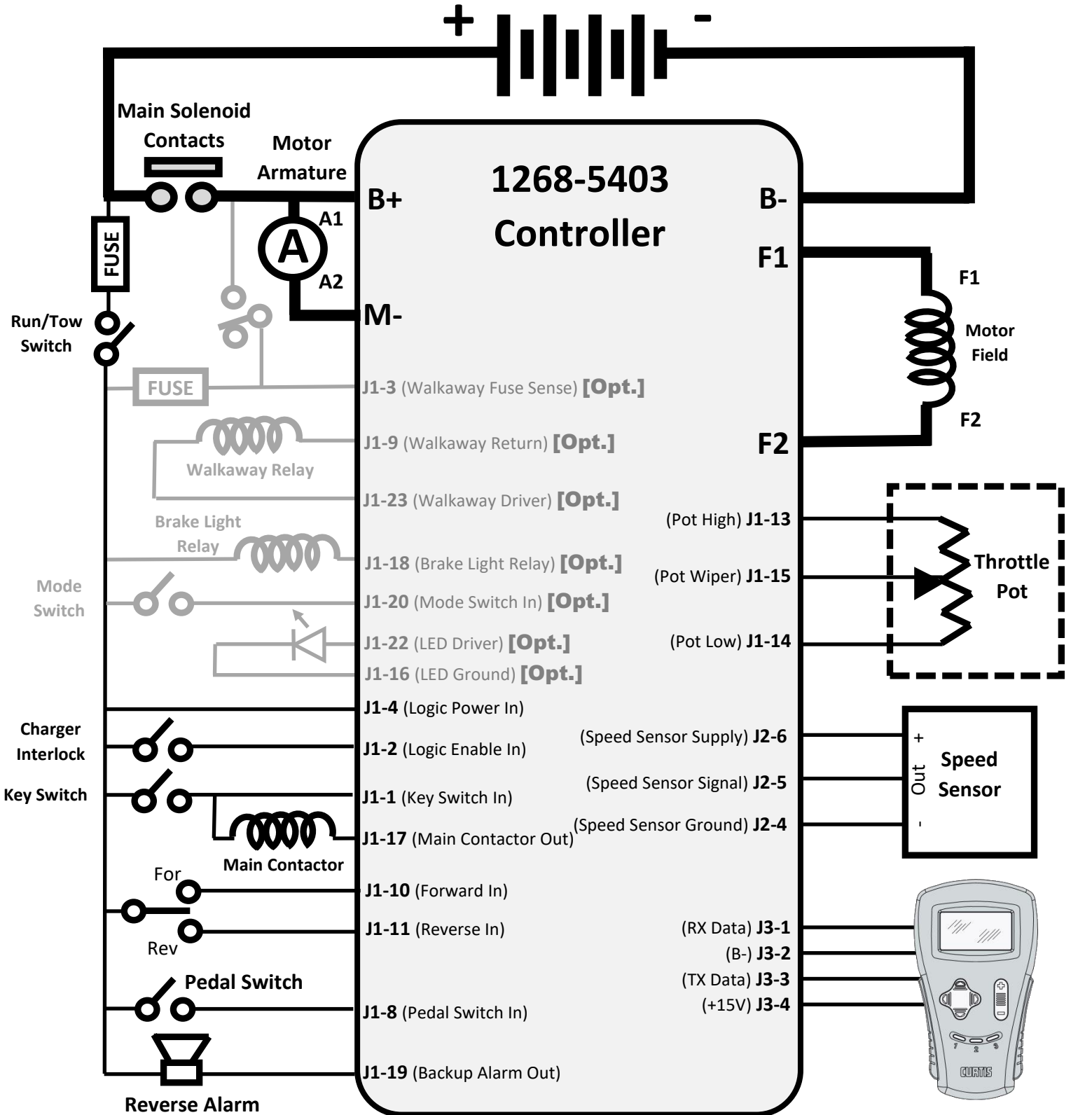

Diagram shows the back (wire) side of controller connector

Generic Golf (1268-5403) Troubleshooting Sequence

FOR SAFETY, ALWAYS LIFT THE DRIVE WHEELS OFF THE GROUND WHEN TROUBLESHOOTING!

THE FOLLOWING TESTS ARE CONDUCTED WITH RUN-TOW/MAINTENANCE SWITCH IN THE RUN POSITION AND WITH A GOOD BATTERY PACK VOLTAGE MEASUREMENT. ALSO, THE CONNECTOR MUST BE ATTACHED TO THE CONTROLLER WHEN MAKING THESE CHECKS. YOU WILL NEED TO 'BACK PROBE' THE PINS FROM THE WIRE SIDE OF THE CONNECTOR. USE A PAPERCLIP IF NECESSARY.

Attach voltmeter negative (-) lead to main Battery Negative (-) for the following tests.

Use the following sequence when checking individual pins (don't skip steps). **If you find a fault, do not move on to the next step until the fault is corrected:**

- Measure the voltage at the main battery positive post (let's call it Pack Voltage)
- Pin J1-4 *Must be Pack Voltage***
 - *If not Pack Voltage, check wiring, Run/Tow switch and fuse for an open condition*
- Pin J1-2 *With Charger Disconnected*, must be Pack Voltage**
 - *If not Pack Voltage, check wiring and charger interlock switch for an open condition*
- Pin J1-1 *With Key Switch Off*, must be equal to 0 volts**
 - *If not 0 volts, check wiring, and Key Switch for a shorted condition*
- Pin J1-1 *With Key Switch On*, must be Pack Voltage**
 - *If not Pack Voltage, check wiring and Key Switch for an open condition*
- Pin J1-17 *Must be Pack Voltage***
 - *If not Pack Voltage, check wiring and solenoid coil (small terminals) for an open condition*
- Pin J1-10 *With F/R Switch in Reverse*, must equal 0 volts**
 - *If not 0 volts, check wiring and F/R Switch for a shorted condition*
- Pin J1-10 *With F/R Switch in Forward*, must equal Pack Voltage**
 - *If not Pack Voltage, check wiring and F/R Switch for an open condition*
- Pin J1-11 *With F/R Switch in Forward*, must equal 0 volts**
 - *If not 0 volts, check wiring and F/R Switch for a shorted condition*
- Pin J1-11 *With F/R Switch in Reverse* must equal Pack Voltage**
 - *If not Pack Voltage, check wiring and F/R Switch for an open condition*
- Pin J1-8 *With Pedal Up*, must equal 0 volts**
 - *If not 0 volts, check wiring and Pedal Switch for a shorted condition*
- Pin J1-8 *With Pedal Down*, must equal Pack Voltage**
 - *If not Pack Voltage, check wiring and Pedal Switch for an open condition*
- Pin J1-19 *With F/R Switch in Neutral*, must equal approximately Pack Voltage**
 - *If not approximately Pack Voltage, check wiring and Reverse Alarm for an open condition*
- Pin J1-19 *With F/R Switch in Reverse*, must equal less than approximately 1 volt (and backup alarm beeps)**
 - *If correct voltage, but no sound from reverse alarm, replace beeper*
- Pin J1-13 *(If no wire in this position then skip step, otherwise)* must equal approximately 5 volts**
 - *If not approximately 5 volts, check connector and wire terminal for being burnt/corroded. If terminal is clean, controller may be defective*

Continued on next page ...

- Pin J1-14** *(If no wire in this position then skip this step, otherwise)* must equal 0 volts
 - If not 0 volts, check connector and wire terminal for being burnt/corroded. If terminal is clean, the controller may be defective
- Pin J1-15** **With Pedal Up**, must be less than approximately .5 volts
 - If not less than approximately .5 volts, check wiring and throttle for shorted condition
- Pin J1-15** **With Pedal Fully Down**, must be more than approximately 4 volts
 - If not more than approximately 4 volts, check wiring and throttle for open condition
- Pin J2-4** **Must equal 0 volts**
 - If not 0 volts, harness and/or harness connector is defective, check wiring
- Pin J2-6** **Must equal 14 to 15 volts**
 - If not 14 to 15 volts, check wiring and check with Speed Sensor removed – if voltage returns to 14 to 15 volts, replace Speed Sensor
- Pin J2-5** **While slowly turning the drive wheel**, must toggle between 0 volts and approximately 5 volts
 - If not toggling, check wiring and if necessary replace Speed Sensor and/or magnet

***** Note: This controller is capable of many optional features and functions that may or may not be present on your cart. *****
See checks below for optional vehicle features

- Pin J1-3** *(If no wire in this position then skip this step, otherwise)* must equal Pack Voltage
 - If not Pack Voltage, check wiring and Walkaway Fuse for an open condition
- Pin J1-9** *(If no wire in this position then skip this step, otherwise)* must equal Pack Voltage
 - If not Pack Voltage, controller may be defective
- Pin J1-23** *(If no wire in this position then skip this step, otherwise)* must equal Pack Voltage
 - If not Pack Voltage, check wiring and Walkaway Relay for an open condition
- Pin J1-23** *(If no wire in this position then skip this step, otherwise)* **while pushing on cart**, must equal approximately 0 volts
 - If not approximately 0 volts, controller may be misprogrammed or faulty
- Pin J1-18** *(If no wire in this position then skip this step, otherwise)*, must equal Pack Voltage
 - If not approximately Pack Voltage, check wiring and Brake Light Relay coil for an open condition
- Pin J1-20** *(If no wire in this position then skip this step, otherwise)* **with Mode Switch open**, must equal 0 volts
 - If not 0 volts, check wiring and Mode Switch for a shorted condition
- Pin J1-20** *(If no wire in this position then skip this step, otherwise)* **with Mode Switch closed**, must equal Pack Voltage
 - If not Pack Voltage, check wiring and Mode Switch for an open condition
- Pin J1-16** *(If no wire in this position then skip this step, otherwise)*, must equal 0 volts
- Pin J1-22** *(If no wire in this position then skip this step, otherwise)*, must toggle between approximately 0 and 2 volts and must be in sequence with the Status LED on top of the controller.
 - If not toggling between approximately 0 and 2 volts, check wiring and remote LED for an open condition

Continued on next page ...

TROUBLESHOOTING CHART

LED CODE	PROGRAMMER LCD DISPLAY	EXPLANATION	POSSIBLE CAUSE
1,1	HW FAILSAFE	Self-test or watchdog fault	1. Controller Defective
1,2	THROTTLE FAULT 1	Wiper Signal out of range (pot low fault)	1. Throttle input wire open 2. Throttle input wire shorted to B+ or B- 3. Throttle pot defective
1,3	SPEED SENSOR FAULT	No pulses from speed sensor	1. Speed sensor not connected 2. Speed sensor defective 3. Speed sensor magnet damaged
1,4	HPD	High Pedal Disable fault	1. Improper sequence of direction and throttle inputs
1,5	MOTOR STALL	Motor stall at current	1. Slope too steep for vehicle weight 2. Mechanically locked motor 3. EM brake wiring fault 4. Speed sensor defective
2,1	LOW BATTERY VOLTAGE	Low battery voltage	1. Battery voltage < under voltage cutback threshold 2. Corroded battery terminal
2,2	OVERVOLTAGE	Overvoltage	1. Battery voltage > overvoltage shutdown threshold 2. Vehicle operating with charger attached 3. Battery disconnected during regen braking
2,3	THERMAL CUTBACK	Over/under temperature cutback	1. Temperature > 85 degrees C or < 25 degrees C 2. Excessive load on vehicle 3. Improper mounting of controller 4. Operation in extreme environment
2,4	MAIN DRIVER ON	Main contactor coil held low	1. Main contactor missing or wire to coil open 2. Controller defective
2,5	AUX COIL FAULT	Missing aux (brake, walkaway relay) coil	1. Aux coil open or not connected
3,1	MAIN DRIVER OFF	Main contactor driver held high	1. Main contactor coil shorted 2. Controller defective
3,2	MAIN WELDED	Main contactor welded	1. Main contactor stuck closed 2. Main contactor driver shorted
3,3	PRECHARGE FAULT	Internal voltage too low at startup	1. External short or leakage path to B- on external B+ connection (lighting, DC-DC converter connected to controller B+?) 2. Controller defective
3,4	FIELD MISSING	Field winding fault	1. Motor field wiring loose 2. Motor field wiring open
3,5	AUX DRIVER OFF	Aux (brake, walkaway relay) driver held high	1. Aux coil shorted 2. Controller defective
4,1	CURRENT SENSE FAULT	Armature or field current sensor fault	1. Controller defective
4,2	DRIVER OVERCURRENT	Contacting driver or aux driver overcurrent	1. Contactor or aux coil shorted
4,3	M- SHORTED	Internal M- short to B-	1. Verify M- and B- cables are not swapped 2. Controller defective
4,4	AUX RELAY DNC	Aux relay did not close	1. Aux relay missing or wire to coil open
4,5	WELDED AUX RELAY	Welded aux relay	1. Aux relay stuck closed 2. Aux relay shorted

Continued on next page ...

TROUBLESHOOTING CHART, cont'd

5,1	KEY SWITCH SRO	SRO fault	<ol style="list-style-type: none"> 1. Key switch not off at power-up 2. Key switch shorted
5,2	MAIN COIL OPEN	Missing main contactor	<ol style="list-style-type: none"> 1. Main contactor coil open or not connected
5,3	AUX DRIVER ON	Aux (EM brake or Walkaway relay) coil driver held low	<ol style="list-style-type: none"> 1. Aux output short to ground 2. Controller defective
5,4	CIRCUIT BRKR OPEN	Circuit breaker or fuse open in Walkaway circuit	<ol style="list-style-type: none"> 1. Breaker/fuse tripped or open 2. Breaker/fuse defective 3. Relay/fuse sense line broken
5,5	MAIN DROPOUT	Main contactor open	<ol style="list-style-type: none"> 1. Main contactor defective

LED DIAGNOSTICS

A built-in Status LED is visible through a window in the label on top of the controller. When the controller detects a fault, the Status LED flashes the 2-digit fault code. The code is flashed continuously until the fault is corrected. For example, code “3,2” – welded main contactor – appears as:

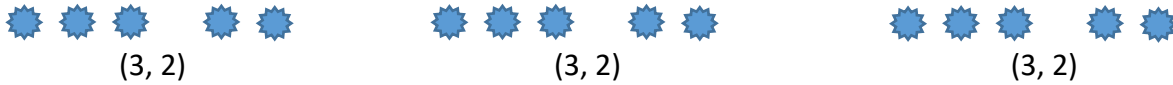

Helpful Hints

- DO NOT UNDER ESTIMATE THE IMPORTANCE OF MOTOR RESISTANCE CHECKS AND MAIN SOLENOID CHECKS. MANY CART ISSUES ARE CAUSED BY BURNT/DAMAGED BRUSHES THAT WILL BE FOUND AS PART OF THE ARMATURE RESISTANCE CHECK. ALSO A SHORTED ARMATURE AND FIELD WITHIN THE MOTOR WILL DAMAGE THIS CONTROLLER.**

Flight Systems Industrial Products also offers the following Technical Support options ...



Troubleshooting Manuals / Codes
www.fsip.biz/TroubleshootingManuals.html



Live Tech Support Chat
www.fsip.biz



Technical Support Forum
fsip.websitetoolbox.com



Frequently Asked Questions
www.fsip.biz/FAQ.html

Phone Support
 1-800-333-1194 (Option 4)

**PRE-INSTALLATION
 INSTRUCTIONS MUST BE
 FOLLOWED OR WARRANTY
 WILL BE VOID**

IMPORTANT!
1268-5403 (0-5K, 0-5V THROTTLE)
TROUBLESHOOTING INFORMATION
INCLUDED IN THIS PACKET